

ME 216 – Engineering Materials II

Chapter 10

Deformation of Metals

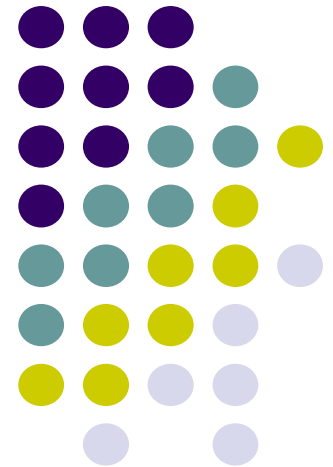

Mechanical Eng. Dept.
Gaziantep University

Prof. Dr. Ömer EYERCİOĞLU
Prof. Dr. Ali Tolga BOZDANA



- **Deformation of metals** is one of the most important aspects of metallurgy. It is related with not only **the formability of metals**, but also **their integrity under service conditions**.
- While some materials are elastic up to point of fracture (e.g. elastomers and most ceramics), **many useful engineering materials (like metals) can undergo substantial plastic deformation prior to fracture**, which makes processing operations possible.
- Deformation of metals takes place by the agency of movement of **dislocations** to cause **slip** (or in some cases, **twinning**). In few cases, **grain boundary sliding** and **diffusional creep** may also take place.
- This chapter covers the principle of dislocations, followed by processes of slip and twinning. Various forming processes will also be described, which make use of deformability of metals to shape them for various useful applications.



- Theoretical strength of metals is generally about 10,000 times more than their actual strength. This discrepancy is due to **dislocations**, which are **line defects inherent in crystals of materials**. In other words, **a dislocation** is an **extra half plane of atoms embedded in a perfect crystal**.

- There may be two components:

- 1. Edge dislocation**
- 2. Screw dislocation**

- Edge dislocation is a **positive type** (i.e. compressive region in the upper half with extra plane of atoms and tensile region in the bottom half).

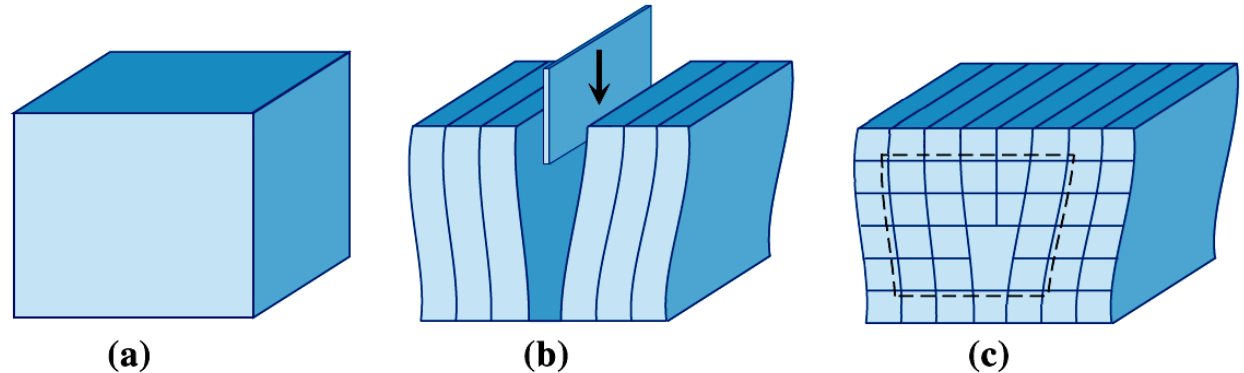

Edge Dislocation: The perfect crystal (a) is cut, and an extra plane of atoms is inserted (b). **The bottom edge of extra plane is an edge dislocation (c).**

- A **negative type** is the opposite dislocation (with extra half plane in the bottom half).

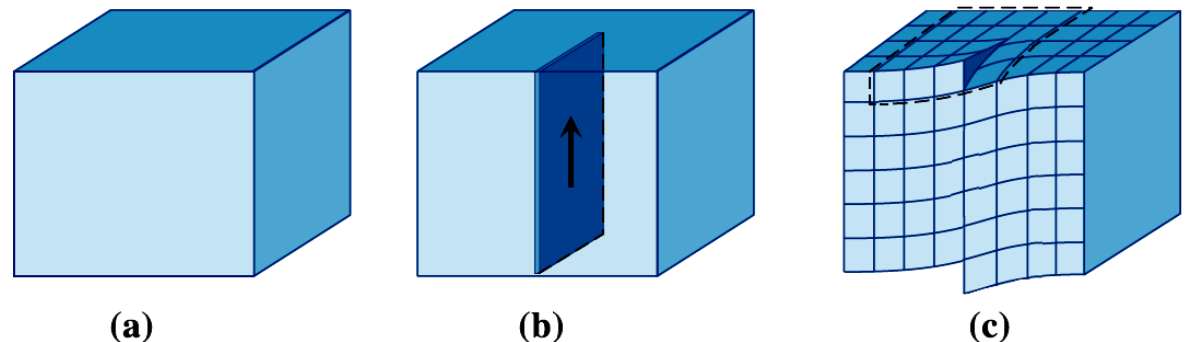

Screw Dislocation: The perfect crystal (a) is cut and sheared one atom spacing (b). **The line along which shearing occurs is a screw dislocation (c).**



- Dislocations are characterized by **Burgers vector (b)**, describing both magnitude and direction of dislocations under an applied force.
- **Burgers circuit (an atom-by-atom circuit around dislocation)** fails to close due to the presence of dislocation. Direction and magnitude of the vector that completes this circuit gives Burger's vector.
- Burgers vector is **perpendicular (in edge dislocation)** and **parallel (in screw dislocation)** to line of dislocation (slip).
- In **mixed dislocation**, the vector makes an angle with dislocation line.

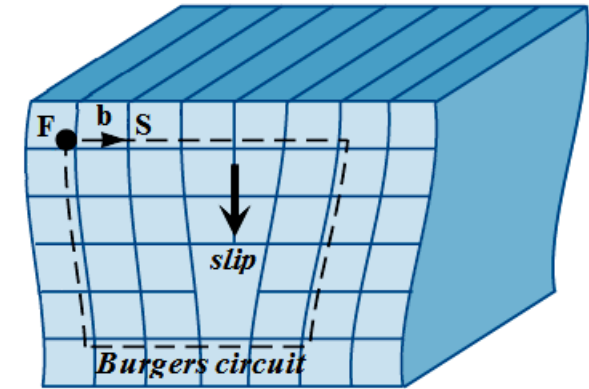

Edge Dislocation

(Burgers vector is perpendicular to slip)

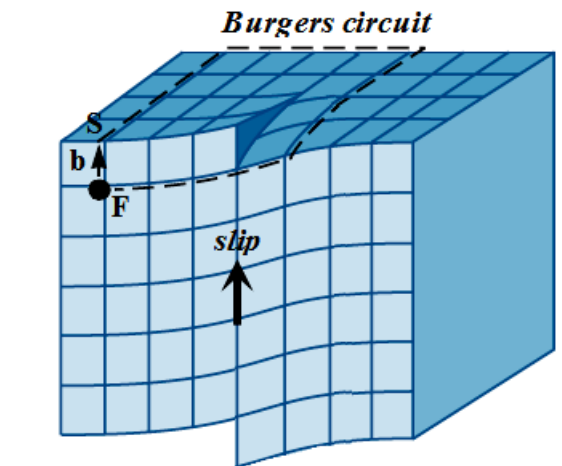

Screw Dislocation

(Burgers vector is parallel to slip)

Mixed Dislocation: A screw dislocation at the front face of crystal gradually changes to an edge dislocation at the side of crystal. Burgers vector remains the same for all portions.

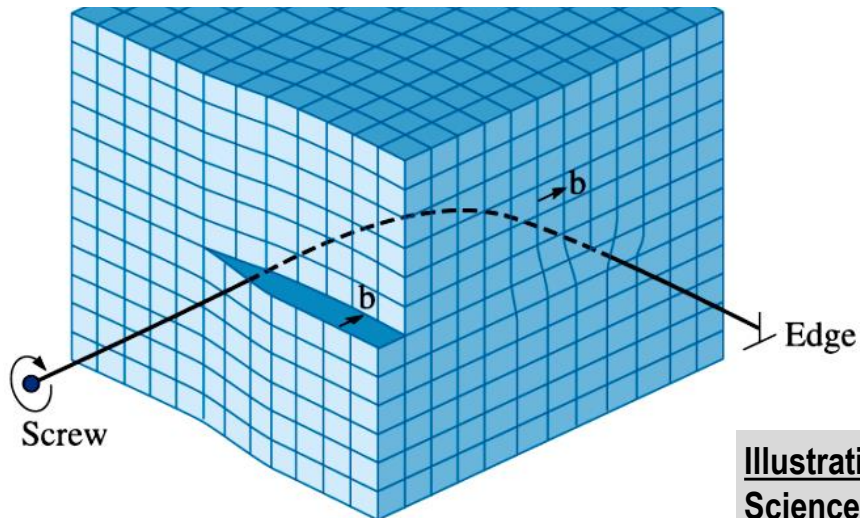

Illustrations are courtesy of: Essentials of Materials Science & Engineering, D.R. Askeland, 2010



- **Dislocations can move** in metals at small applied stresses. This is due to the fact that **atomic bonds are not truly broken** during process. When a dislocation (extra half plane of atoms) moves through a crystal, atomic bonds with **an atom "being left behind"** must be broken so that new bond with **an atom "being approached"** can be established. This occurs easily **by the fact that metallic bonding is relatively non-directional** (being held by a cloud of electrons around nuclei).
- Consider the movement of an edge dislocation under **an applied shear stress (τ)**. This stress must first break the bond between **atoms 1 & 2** so that **atom 1** is pulled away from **atom 2**. Meanwhile, **atom 3** moves towards its equilibrium position with respect to **atom 4**, releasing its stored elastic strain energy.
- Thereby, process of moving **atom 1** becomes easier due to **the release of strain energy** by **atom 3**, and hence movement of dislocation carries on one step at a time until dislocation moves completely toward right and emerges to produce a slip.

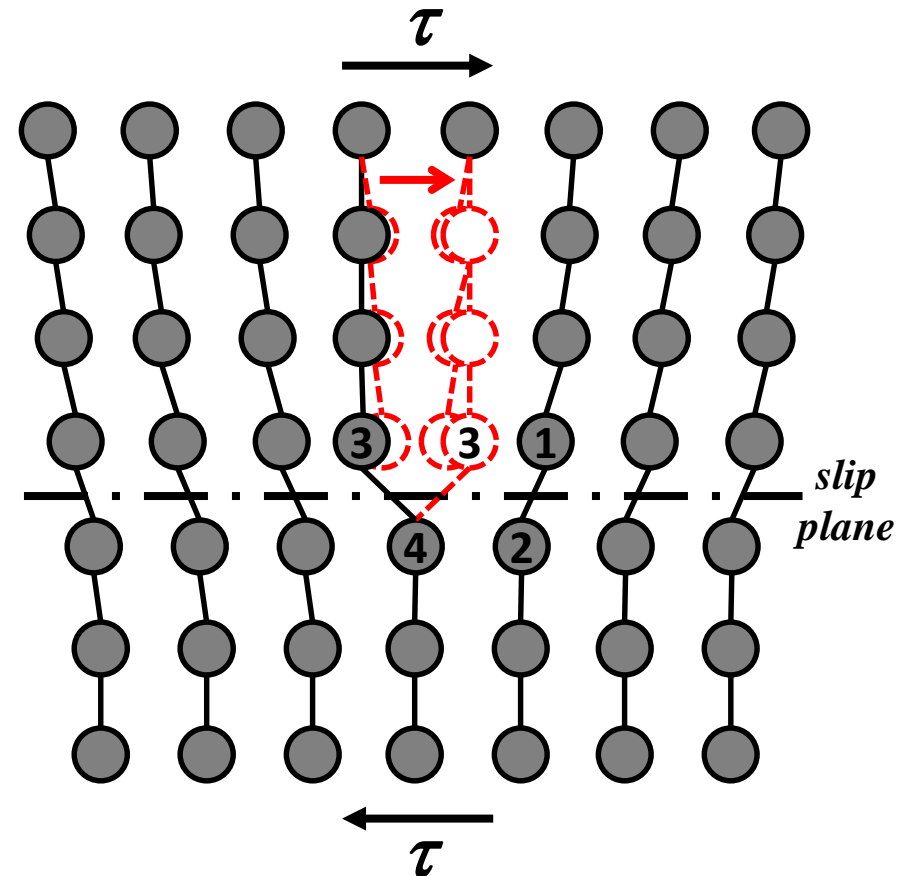

No movement of dislocations, no deformation!!!



Analogy between caterpillar and dislocation motion

Courtesy of:
Fundamentals of Materials
Science & Engineering,
W.D. Callister, 2012

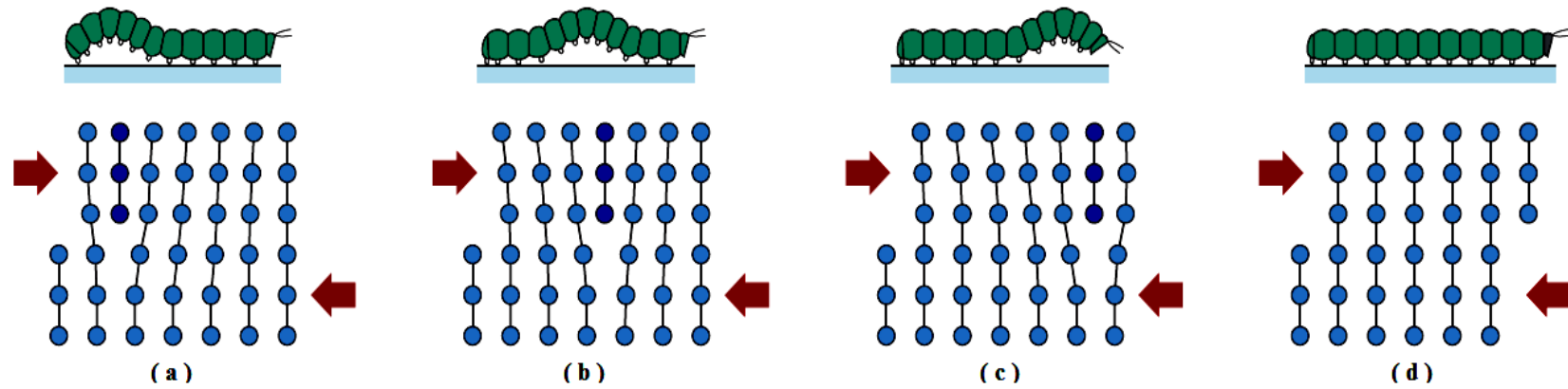

Slip caused by movement of edge dislocation

Courtesy of:
Physical Metallurgy &
Advanced Materials,
R.E Smallman, 2007

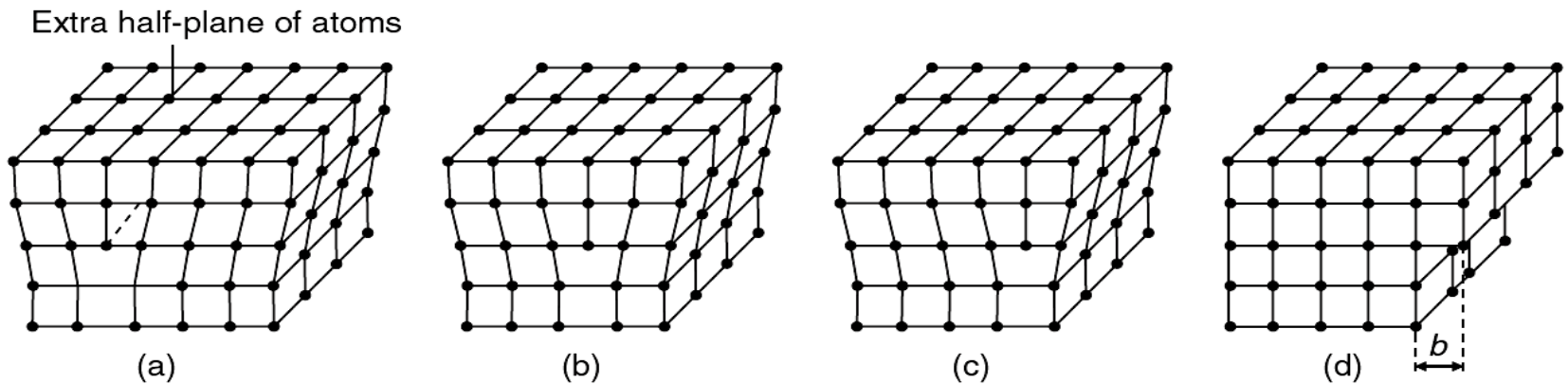

Slip caused by movement of screw dislocation

Courtesy of:
Physical Metallurgy &
Advanced Materials,
R.E Smallman, 2007

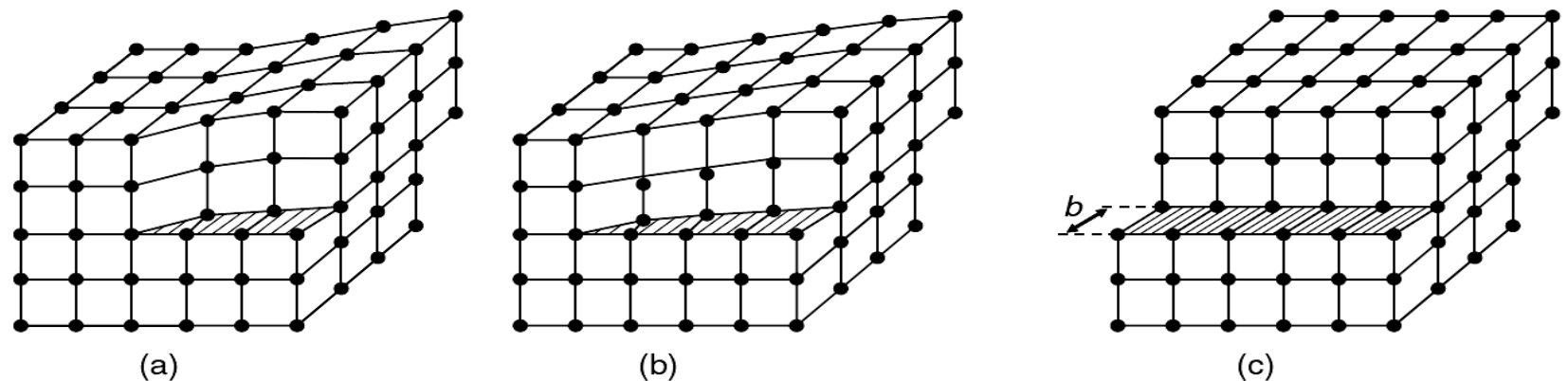



- A very low stress is required to move a single, isolated dislocation through a crystal where the strain produced when it runs out of crystal is also small. Thus, **generation of macroscopic strain requires cooperative motion of a very large number of dislocations.**
- All metals and alloys contain some dislocations that were introduced during solidification, during plastic deformation, and as a consequence of thermal stresses that result from rapid cooling. **Dislocation density in a material** (i.e. **the number of dislocations**) is expressed as **the total dislocation length per unit volume (mm/mm^3)**, or equivalently **the number of dislocations that intersect a unit area of a random section (mm^{-2})**.
- In carefully solidified metal crystals, dislocation densities are as low as 10^3 mm^{-2} . For heavily deformed metals, the densities may run as high as 10^{10} mm^{-2} . **Heat-treating a deformed metal specimen can diminish the density** to the order of 10^6 mm^{-2} .

Work-Hardening and Recrystallization



- In many metal-working processes, there is a limit for the amount of strain to which a part may be subjected without danger of cracking or tearing. In order to extend this limit, the material is annealed above its recrystallization temperature for a predetermined period of time.
- This treatment produces new, strain free grains. This way, a large number of dislocations is eliminated. In other words, the softened material can undergo further deformation.

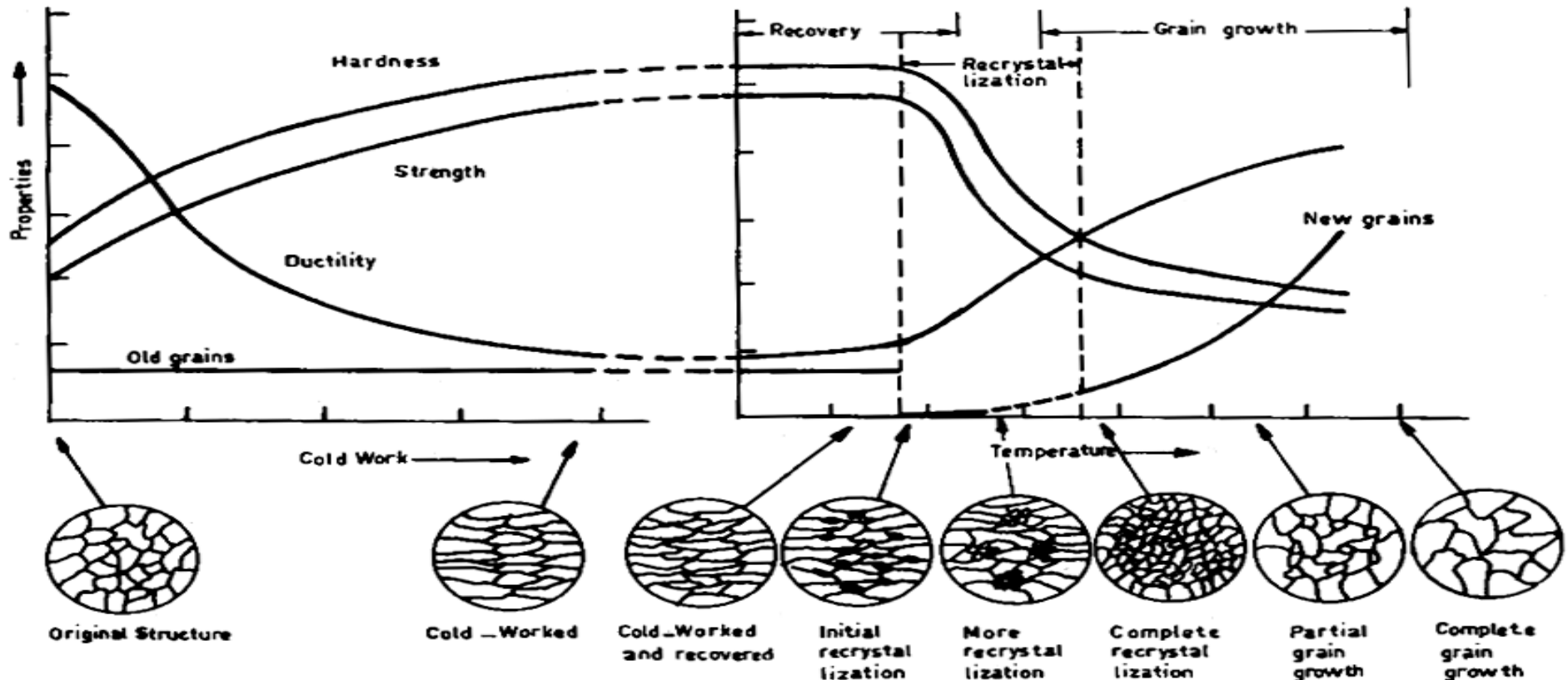



- Interstitial and substitutional atoms affect movement of dislocations. **Hard, second-phase particles (precipitates)** distributed in a matrix behave similarly, but to a very large extent.
- A dislocation moving in a matrix meets **a precipitate that does not shear as easily as matrix**. The dislocation is arrested by particle in its motion, and **starts to bulge**. After bulging through between particles, the dislocation line re-forms, leaving a dislocation loop (**Orowan looping**) around the particle.

- Each additional dislocation would leave another loop, which **increases its size and decreases the spacing between them**. So, an ever-increasing stress is required to push successive dislocations through.
- This is called **precipitation (dispersion) hardening**, which is the most effective when the particles are small and coherent with the matrix lattice.

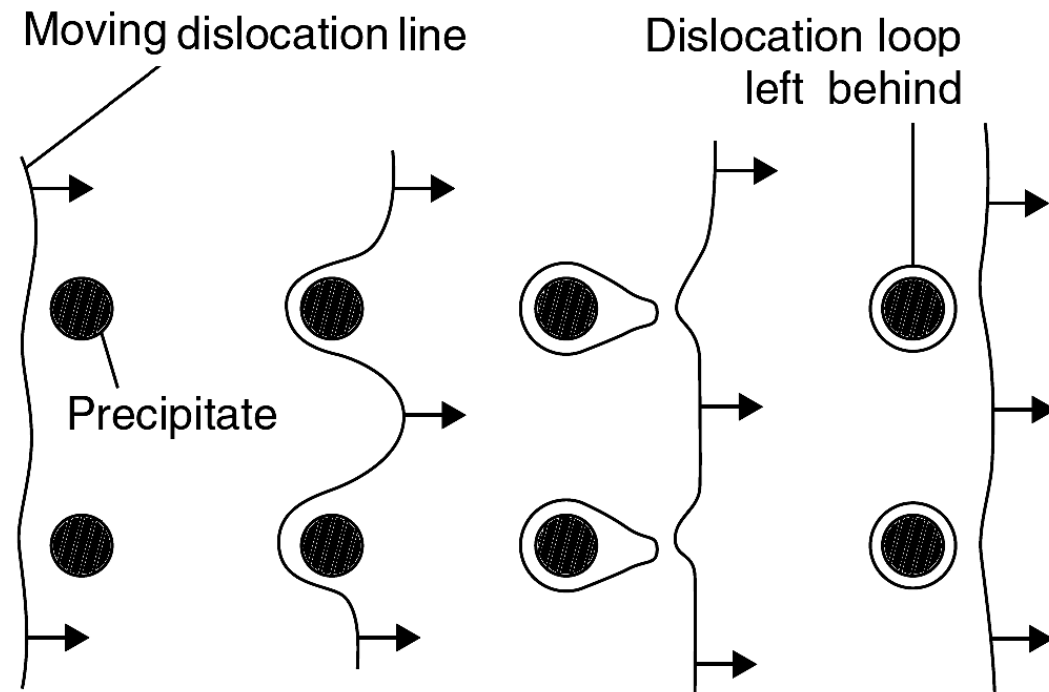

Courtesy of: Physical Metallurgy & Advanced Materials, R.E Smallman, 2007



- **Slip** marks the onset of plasticity in metals. Under an applied stress, metal undergoes elastic deformation whereby it gains its original size on removal of stress. Once the critical stress is reached, metal is permanently deformed due to plastic deformation caused by slip.
- Such plastic deformation involves sliding of atomic planes relative to each other within crystallographical manner. Displacement occurs on specific crystallographic planes in specific crystallographic directions.
- The combination of slip plane and its direction refers to slip system.
- Slip occurs in direction where atoms are most closely packed as this requires the least amount of energy.
- Close-packed rows are vertically more apart ($d_1 > d_2$) and horizontally less apart ($D_1 < D_2$) from each other than rows that are not close-packed.

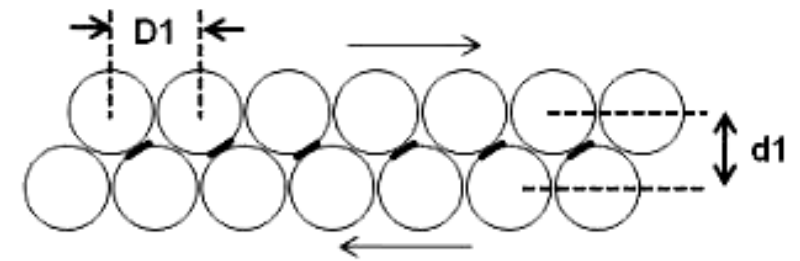
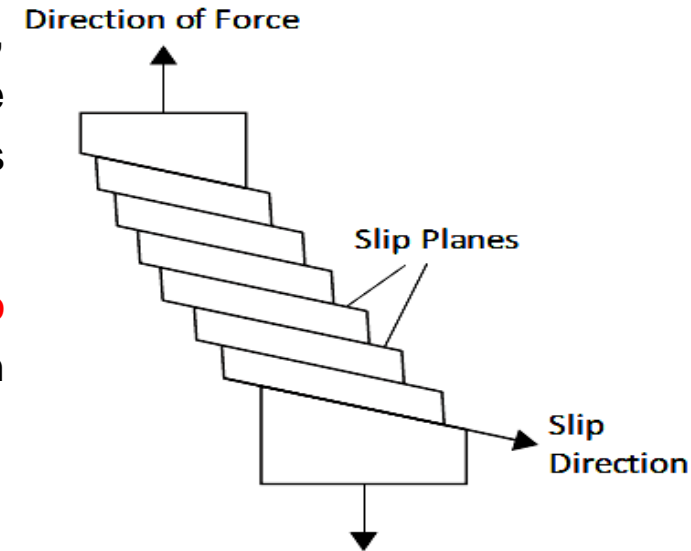

Closed packed planes, atoms can slip easily

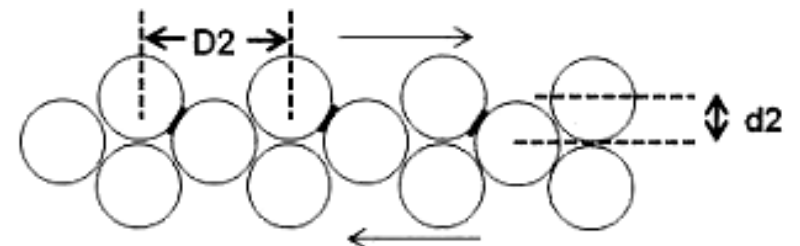

Not so closed packed planes, atoms slip not so easily



- On a microscopic scale, **slipping is not uniform**, but it is **localized on slip planes** and within **slip bands**.
- Spacing between slip planes in a slip band may be 200 Å (i.e. about 100 atomic diameters) whereas the separation of adjacent bands may be 100 times greater (i.e. 20,000 Å). Slip on each plane may be of several micrometers.
- **Along with increase in the magnitude of applied stress, the number of active slip planes and the distance of slip along these planes also increases.**

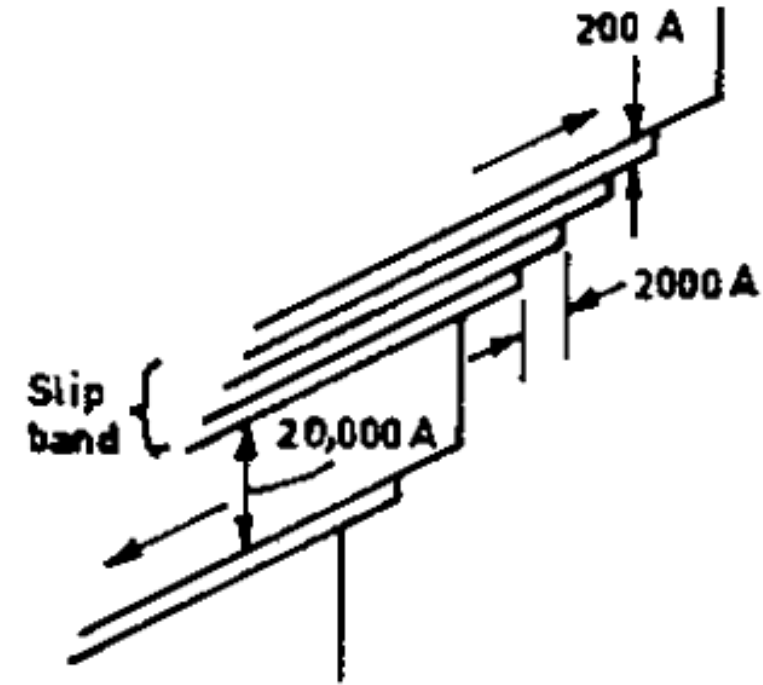



- To understand the fundamentals of plastic deformation, tensile test is carried on **single-crystal materials**.
- For this purpose, metallurgists develop **whiskers** (fibers of $\text{Ø}1 \mu\text{m}$) that are essentially **dislocation-free**.
- Figure shows behaviour of **Cu-whisker** under tensile load, which demonstrates the role of dislocations in causing slip in metals.
- Dislocation-free whisker **does not flow plastically up to 750 MPa**. When dislocations occur due to the high stress levels, **a sharp discontinuous drop in stress** occurs **due to yielding** assisted by the motion of these dislocations.

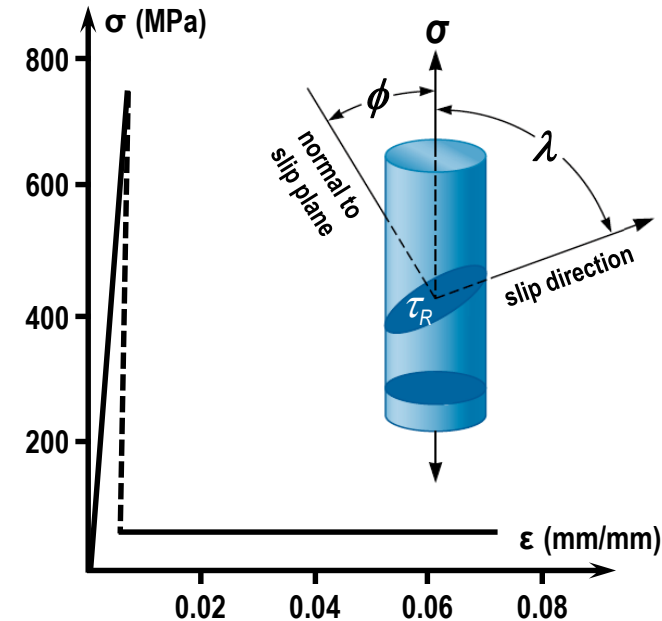

- **Resolved shear stress (τ_R)** is dependent upon applied stress (σ) and orientation of stress direction relative to normal to slip plane (ϕ) and to slip direction (λ): $\tau_R = \sigma \cos \phi \cos \lambda$

- Yielding occurs at **critical resolved shear stress (τ_{crss})**: $\tau_{crss} = (\tau_R)_{\max}$

- Thus, **yield strength (σ_y)** is determined as: $\sigma_y = \frac{\tau_{crss}}{(\cos \phi \cos \lambda)_{\max}}$

- Minimum stress for yielding is obtained when single-crystal is oriented as: $\phi = \lambda = 45^\circ \rightarrow \sigma_y = 2\tau_{crss}$

Slip in Polycrystalline Materials



- Deformation in polycrystalline materials is **similar, but much more complicated** as compared to single crystals.
- **Such complication arises from grain boundaries** due to constraints on flow of a given grain by its neighbors and by flow of the aggregate.
- Due to this complication, **stress required to initiate flow in polycrystal is increased**. Although some grains are favorably oriented for slip, yielding cannot occur unless unfavorably oriented neighboring grains are also able to slip. **Once yielding occurs, plastic deformation continues only if enough slip systems are simultaneously operative** to accommodate grain shape changes.
- **At least five independent slip systems must be mutually operative for polycrystalline solid to exhibit ductility**. Polycrystalline-Zn (with only three slip systems at room temp.) fractures after very small amount of plastic strain while polycrystalline-Cu (with 12 slip systems) exhibits extensive plastic flow prior to fracture.
- **Yield strength of polycrystals increases with decreasing grain size**, since grain boundaries act as internal barriers to dislocation motion.

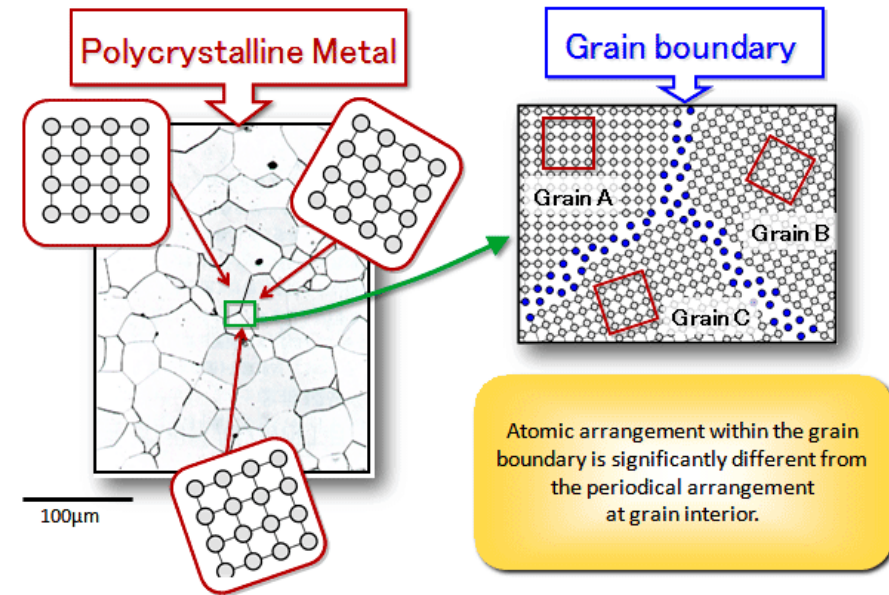

Slip lines on the surface of polished and subsequently deformed polycrystalline-Cu

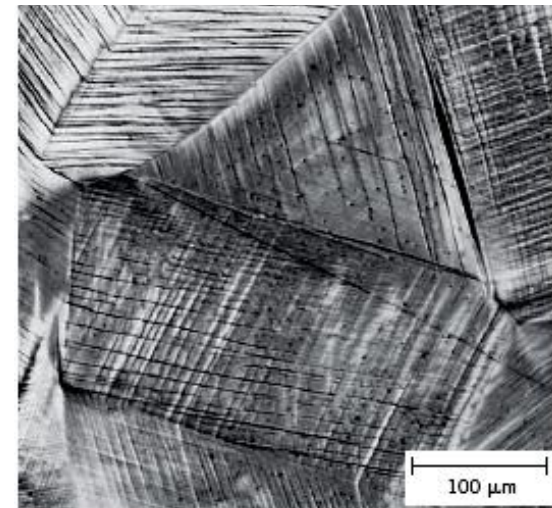



- **Twinning** is a second mechanism of plastic deformation, in which one portion of a crystal lattice is mirror image of the other.
- **Twin plane** is crystallographic plane of reflection.
- **Twins are formed during growth of a crystal or produced mechanically** (due to a homogeneous shear of successive planes of atoms by the amount of twinning vector parallel to twin plane).

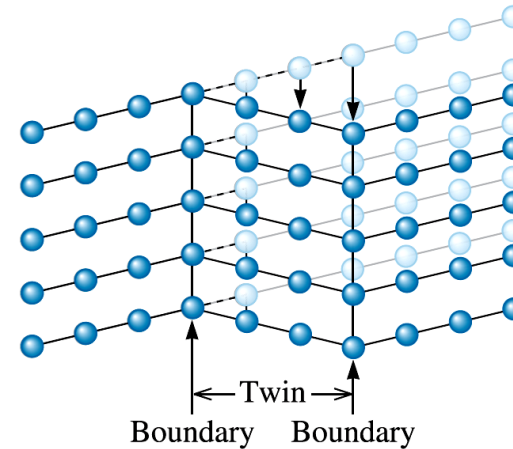

- **Mechanical twinning differs from slip:**
 - the twinning portion of a grain is the mirror image of original lattice, whereas the slipped portion of a grain has the same orientation as original grain.
 - slip consists of shear displacement of an entire block of crystal, whereas twinning is a uniform shear strain.
 - direction of slip may be positive or negative, while direction of twinning is defined by its mirror image.

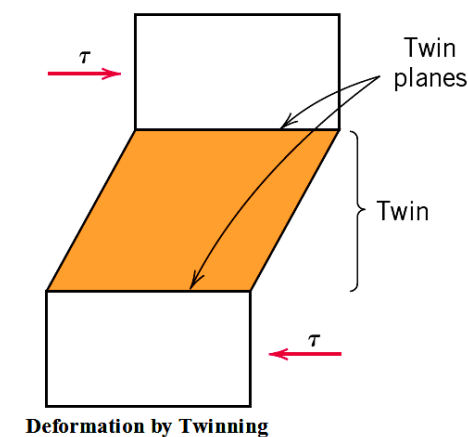
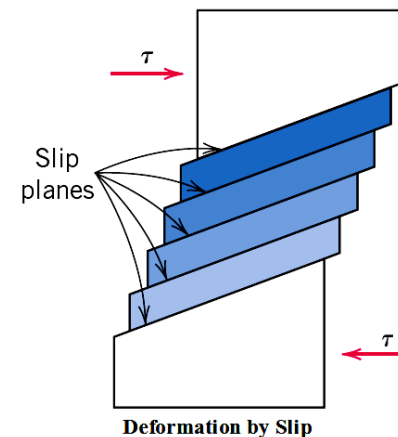

Fundamentals of Materials Science & Engineering, W.D. Callister, 2012

- The stress required for twinning is higher than that for slip, and also less sensitive to temperature.
- The stress required to grow a twin is less than that required to initiate it.



➤ Metals are converted into useful shapes by various forming processes:

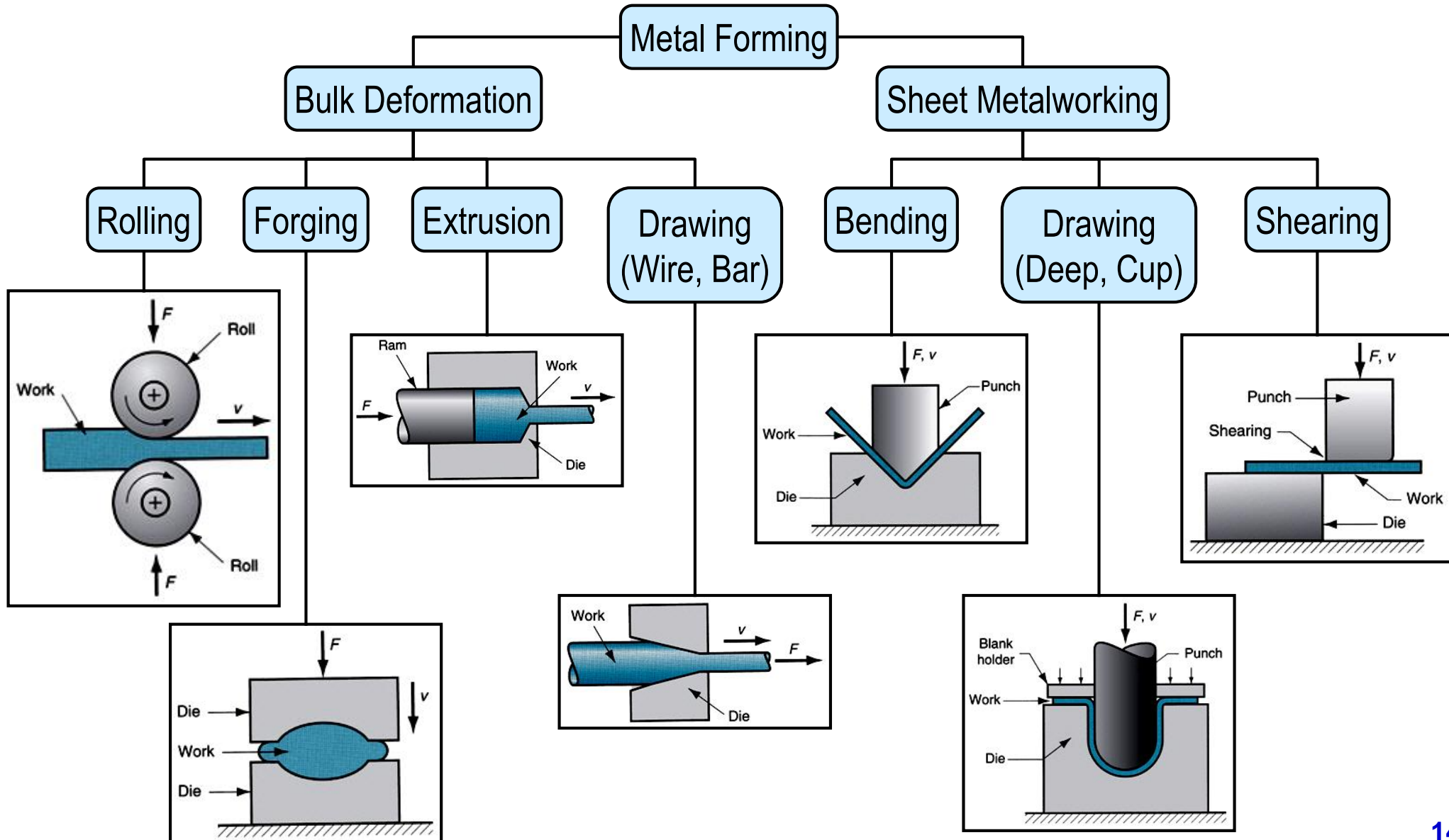



- According to working temperature, these forming processes are divided into two groups:

Hot Working

- ① carried out **above recrystallization temperature**
- ① operations: *rolling, forging, extrusion, drawing*
- ☺ produces **fine, strain-free grains**
- ☺ gives **uniform properties** (elimination of porosity and inclusion segregation)
- ☹ **bad surface finish**
- ☹ **close dimensional tolerances not maintained**
- ☹ **oxidation and scaling** (due to high temperature)
- ☺ **economical** (less energy required for deforming)
- ☺ **high production rate**

Cold Working

- ① carried out **below recrystallization temperature**
- ① operations are classified as:
 - *sequeezing (rolling, impact extrusion)*
 - *shearing (blanking, piercing)*
 - *drawing (wire and tube drawing, spinning)*
 - *bending (roll forming, seaming)*
- ☺ **increase in strength**
- ☹ **decrease in ductility**
- ☹ causes **high strain** (to be removed by annealing)
- ☹ suitable only for **ductile and malleable materials**
- ☺ **good surface finish**
- ☺ **close dimensional tolerances are maintained**
- ☹ **relatively expensive** (high energy required)
- ☹ **low production rate**