

ME 216 – Engineering Materials II

Chapter 3

Metals and Alloys

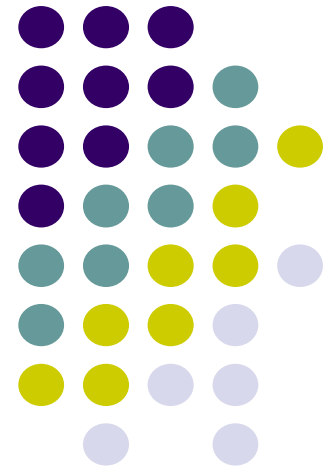

Mechanical Eng. Dept.
Gaziantep University

Prof. Dr. Ömer EYERCİOĞLU
Prof. Dr. Ali Tolga BOZDANA



- Two most important constituents of our world are **matter** and **energy**, which have been shown by Einstein to be interrelated.
- The relationship is based on **the atomic structure of matter which forms the basis of energy.**
- **Neither matter nor energy can be created or developed, but can only change forms.**
- These physical laws play very important role in metallurgical energy as it deals with **changes of structure and forms with heat and mechanical energy.**
- In order to understand the implication of these laws and the changes in metal structures, an engineer should have **the knowledge of atomic arrangements and structure of metals.**
- An understanding of atomic structures also makes it easier to comprehend **the changes that take place in atomic scale to produce compounds and alloys** as well as their behaviour under the influence of heat or mechanical energy.



- **Matter is composed of atoms** that are too small to be seen with ordinary microscopes, but the outline of molecules has been detected by **field ion and electron microscopes**.
- **A molecule is defined as the smallest particle of any substance** that can exhibit all chemical properties of that substance. **A molecule may consist of one or more atoms.**
- **Matter compound of a single kind of atom is called an element.** There are **more than 100 elements**, and new ones are being discovered all the time. Those with atomic number of higher than 92 are not found in nature, but are produced by atomic reactions such as in nuclear reactions. There are two types of elements: **Metals and Nonmetals**
- **A compound is composed of two or more elements combined chemically** whereas **physical mixture of two or more elements is called a mixture.** For instance; *hydrogen and oxygen* combine chemically to form water (which is *a compound*) while *sugar and salt* can only mix physically to give *a mixture*.



- **An atom** resembles mini-scale solar system having orbits in many planes.
- It consists of **neutrons**, **protons** and **electrons** although recent research in particle physics has discovered even smaller constituents of atoms.
- **Nucleus** of atom consists of **protons** and **neutrons** meanwhile **much smaller electrons** revolve around nucleus at very high speeds.

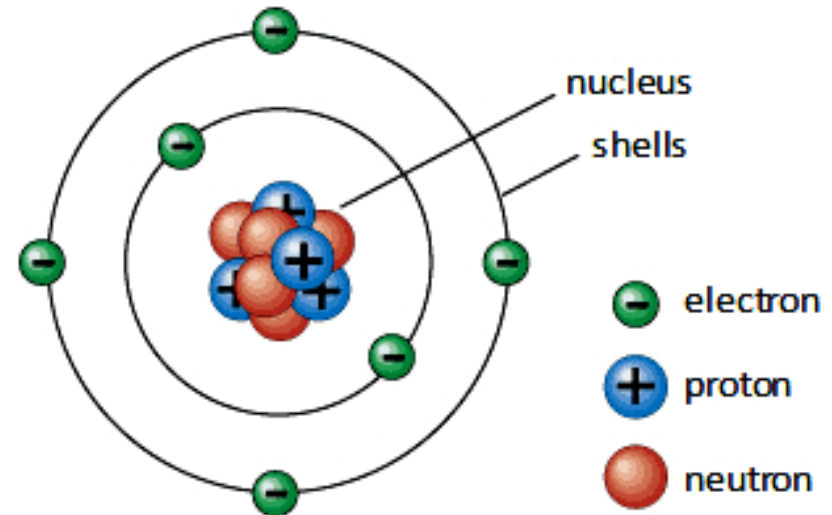

- **Protons** have a **positive electrical charge**. **Neutrons** weigh the same as protons, but **do not carry any charge**. **Electrons** are **negatively charged** and strongly attracted to the positively charged nucleus.
- **Each atom has preferred electron paths or orbits (shells)**. Each shell contains a given number of electrons for each atom. Number, arrangement and spin of the electrons in shells together with the constituents of nucleus determine the kind of atom and its characteristics.



- Total number of electrons in atom is called **atomic number of an atom**.
- Total number of protons and neutrons in nucleus is called **atomic weight of an atom**.
- Number of protons also equals the atomic number in a stable atom since they balance the electrical charge of an electron. If number of electrons and protons are not the same, then the atom displays electronic charge and becomes unstable.

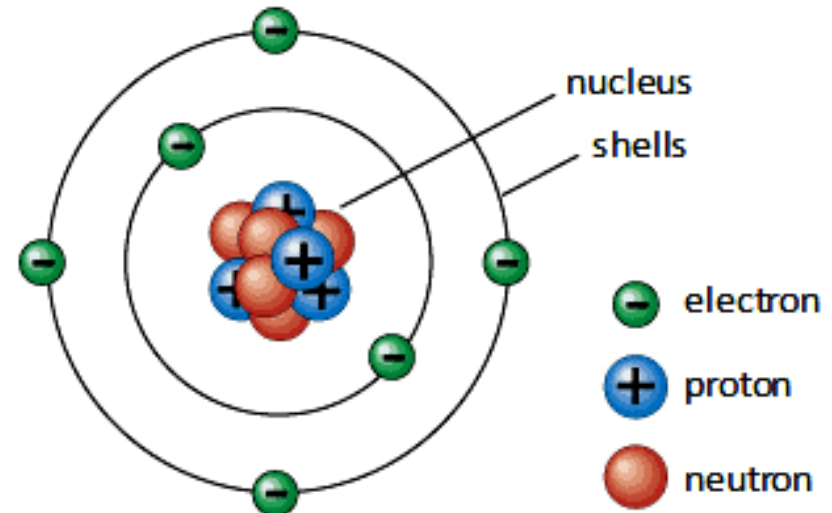

- **Electrons in the outermost shells (valence electrons)** are the most important electrons. **They determine physical and chemical properties of an atom.**
- The most stable (the lowest energy) condition for an atom is obtained when the outermost shell is complete with a full compliment of electrons. If an atom has less than complete quota of electrons in its shell, it tries to either acquire or release some electrons to complete its valence shell. Number of valence electrons determine the way that an atom completes its valence shell, and thus they play a vital role in determining the characteristics of that atom.





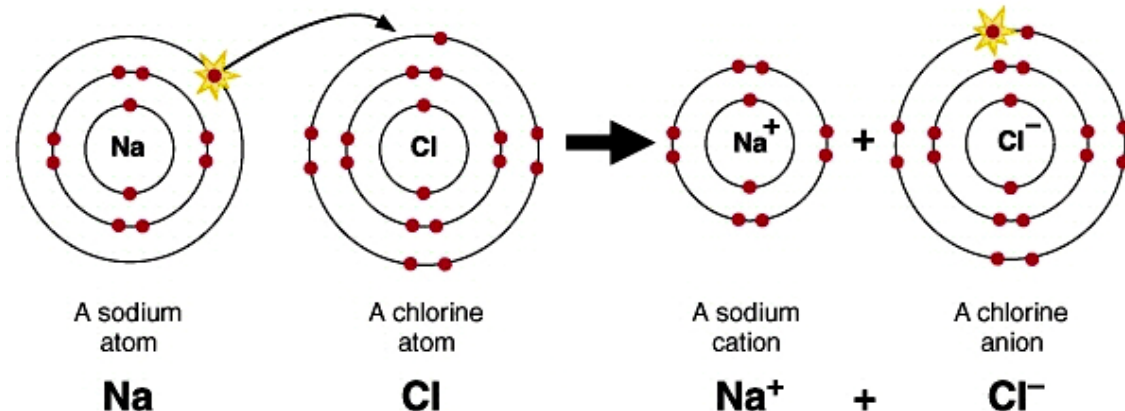



- There are various ways in which atoms can join together to form molecules depending upon the character of atoms involved. **Basic types of bonding arrangements:** *ionic, covalent, metallic, van der Waals forces*
- In an ionic bond, an element having one valence electron releases it to complete its outer shell. On the other hand, an element having one less electron in its valence shell finds it easier to acquire it from a donor to complete the valence shell.
- For instance, **sodium (Na)** has one valence electron to release and complete its valence shell rather than acquire seven more electrons. However, **chlorine (Cl)** has seven electrons, so it is easier to acquire one electron rather than release seven electrons.
- Thus, **Na** (one less electron) acquires positive charge, **Cl** becomes negative (due to extra electron). As a result, an electronic attraction is developed and ionic bond is formed.
- However, **this structure is weak and brittle** as the electrostatic forces are very selective and directional.

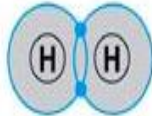

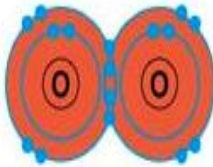

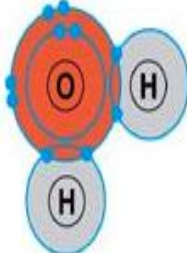
- **A covalent bond** is based on **sharing electrons by atoms involved**.
- For instance, **oxygen (O)** has six valence electrons and it can complete its valence shell by acquiring two electrons. This is considerably difficult, so it shares two electrons with another oxygen atom. This arrangement completes outer shells of both oxygen atoms to produce **oxygen molecule (O₂)**.
- This type of bonding is **very strong**, and bonding strength **depends on number of shared electrons**.
- It generally occurs in non-metals such as carbon (diamond bond), and it gives rigid and directional structure (like in ionic bond).

Name (molecular formula)	Electron-shell diagram	Structural formula	Space-filling model
Hydrogen (H ₂)		H—H	
Oxygen (O ₂)		O=O	
Water (H ₂ O)		$\begin{array}{c} \text{O} - \text{H} \\ \\ \text{H} \end{array}$	



- **Metallic bonding** is **peculiar to metals only**. It is formed among similar metal atoms such that some valence electrons leave their respective atoms to form a cloud surrounding positively charged ions. When valence electrons leave an atom, it becomes a positively charged ion.
- The cloud surrounds all positively charged ions, and hence these ions arrange themselves in a very orderly manner and are held in their place due their attraction by negatively charged electron cloud surrounding them.
- The electrons in cloud are free to move all over the metal, therefore the metals exhibit good electrical and thermal conductivity as well as good elasticity and plasticity.
- The metallic bond is **very strong**.

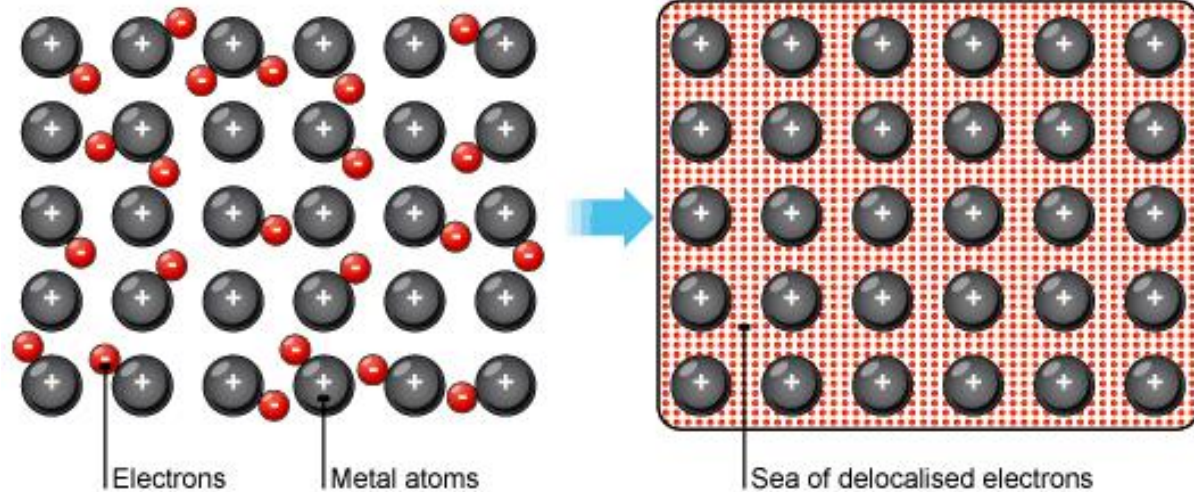

- **Van Der Waals forces** are **very weak**, and **formed in neutral atoms** such as inert gases.
- They only become important for **metals at low temperatures**.



- **Metals** have a very definite arrangement of atoms and specific structures.
- The metallic bond imparts certain characteristics to metals which distinguish them from nonmetals. A metal has the following properties:
 - *Ability to donate electron, and hence become positively charged ion*
 - *Crystalline structure*
 - *High thermal and electrical conductivity*
 - *Ability to be deformed plastically*
 - *Metallic lustre*
- Some elements (e.g. **silicon** and **germanium**) possess one or more of these properties, and they are termed **metalloids**.

- Metals in solid state have a definite arrangement of atoms, called **crystalline structure**.
- When a metal is in liquid form above its melting temperature, the atomic forces are reduced and the atoms can move freely within the limits of molten mass.

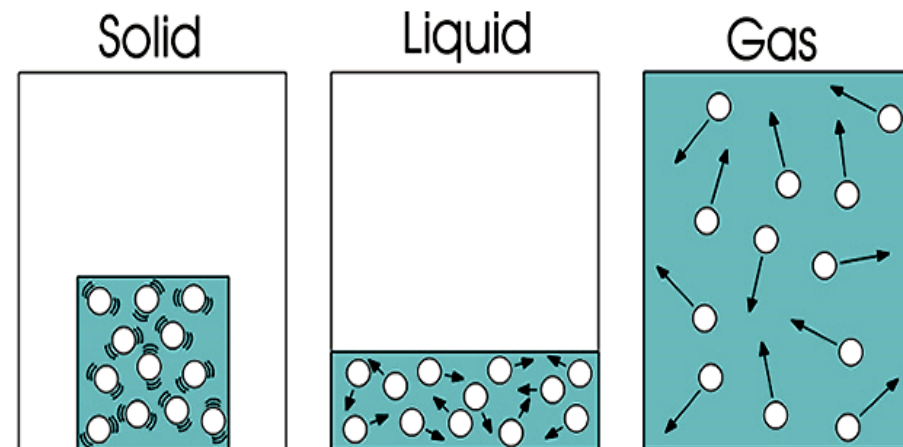



- When the temperature is reduced, the thermal energy available to the atoms is also reduced.
- Consequently, their motion is limited until a temperature is reached where the atoms are no longer able to move from their definite arrangement resulting from metallic bond.
- This temperature is **the solidification temperature at which the force between atoms is greater than thermal activity of atoms**, and thus atoms are unable to leave the arrangement.
- This arrangement of atoms into a definite pattern is called **a space lattice** (i.e. **a series of points in space arranged in a pattern**).
- Space lattice has a single pattern that is repeated again and again. **This recurring single pattern** is called **the unit cell**.
- A unit cell is specific to a space lattice, and space lattices are generally described in terms of unit cells. **Space lattice consists of millions of unit cells joint together.**

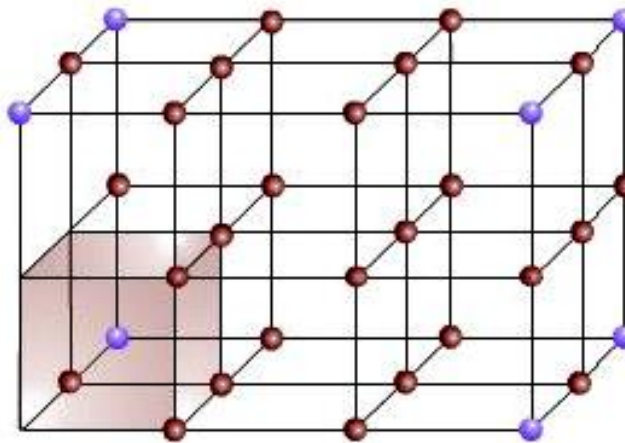

Representation of space lattice and unit cell

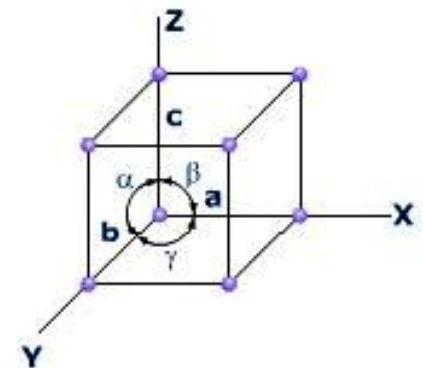

Representation of dimensions of a unit cell



- When a metal begins to solidify, **the free atoms start to condense not just at one site, but at many sites**; and each of these sites grows by the addition of unit cells to create space lattices which continue to grow as the temperature is lowered.
- Just before the completion of solidification, **these adjoining space lattices having different orientations meet each other**. Due to differences in orientations, they do not join each other coherently, and hence **a boundary interface (grain boundary)** is created between them.
- **Each grain in the metal is a space lattice, and the interface between the space lattices is a grain boundary.**
- The nature of these boundaries is not well understood yet. However, it is believed that they are only one or two atoms wide, forming an interlocking border in a highly strained condition.

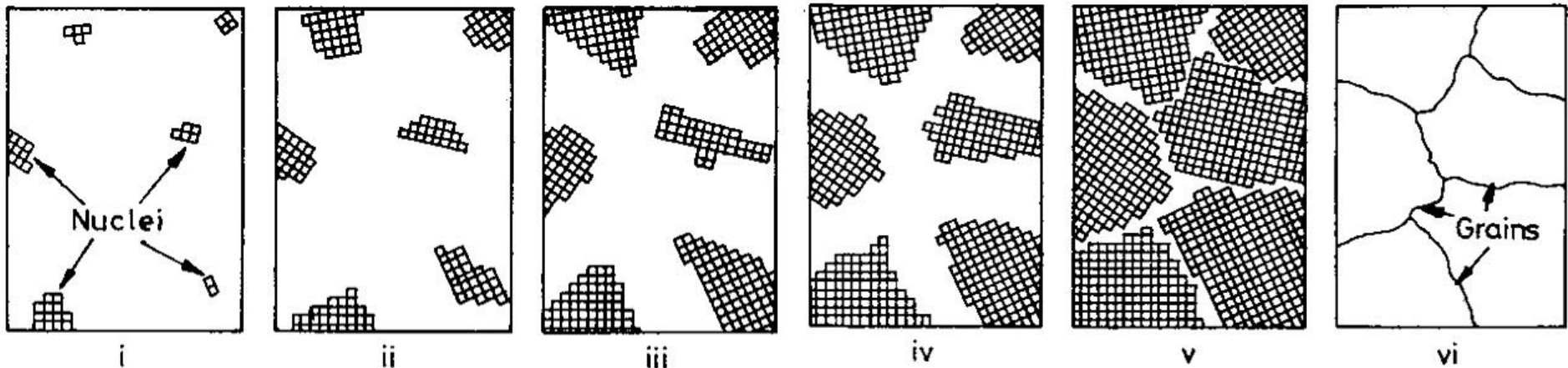



- Arrangements of unit cells in metals (space lattices) can be observed by using **X-ray diffraction**.
- In a metal, there are **14 possible types of unit cells (Bravais lattices)** based on **7 basic geometries**: *cubic, tetragonal, orthorhombic, monoclinic, triclinic, hexagonal, trigonal (rhombohedral)*
- Geometry of space lattice is specified satisfactorily by its lattice constants: *vector lengths (a,b,c)* and *inter-axial angles (α, β, γ)*
- The arrangements are categorized as follows:
 - **Primitive (P)**: atoms occupy only the corners of lattice
 - **Body-centred (I)**: atoms occupy the lattice corners and an additional atom at the gravitational center
 - **Face-centred (F)**: atoms occupy the lattice corners and centers of the each face of lattice
 - **Base-centred (C)**: atoms occupy the lattice corners and basal face centers of lattice

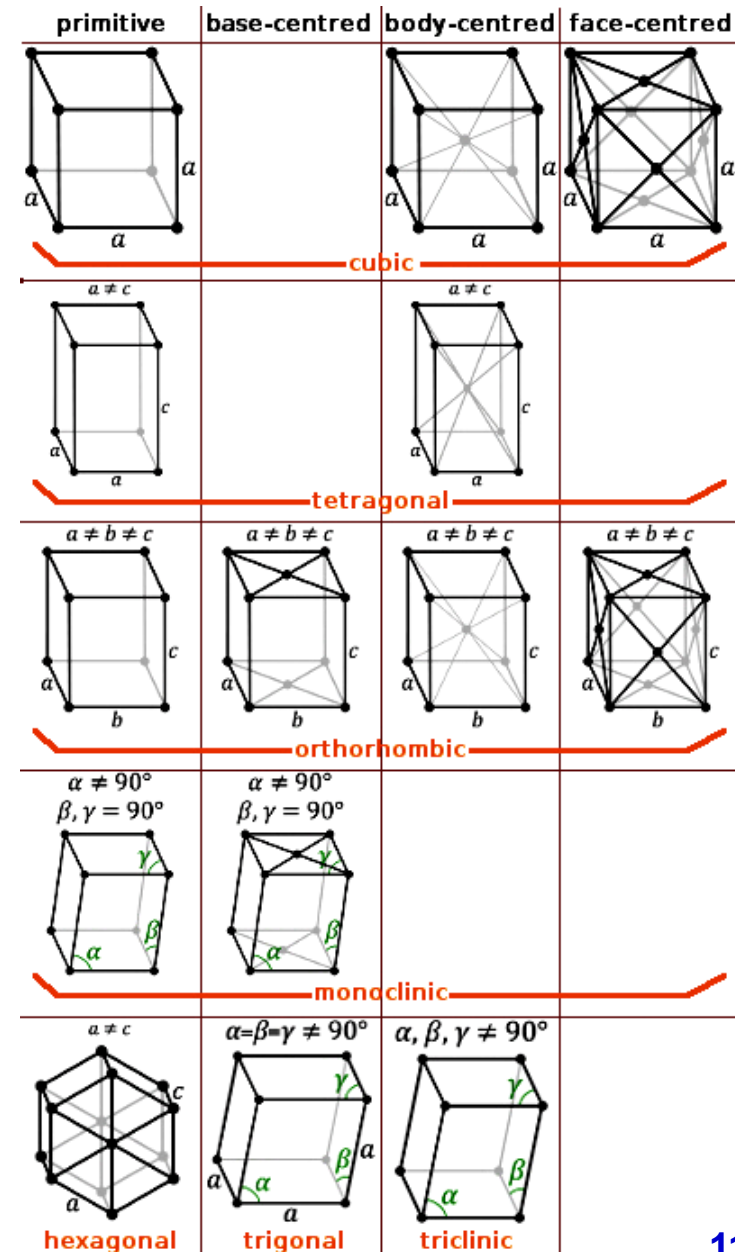

Body-Centred Cubic (BCC)

- α -Fe (ferrite), V, Cr, Mo, W, Ta
- **simpler structure**

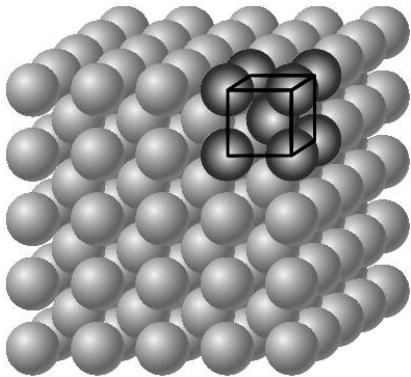
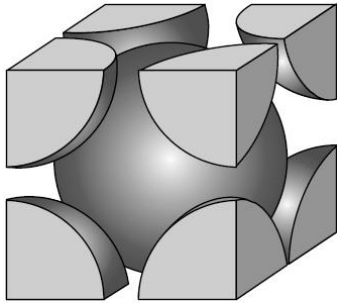
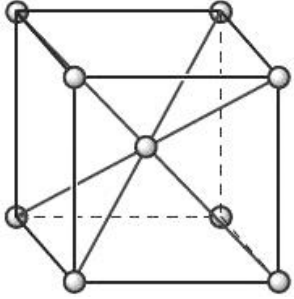

Face-Centred Cubic (FCC)

- γ -Fe (austenite), Al, Ni, Cu, Ag, Pt, Au
- **lower yield strength, higher ductility**

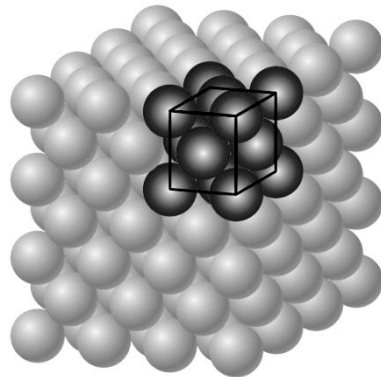
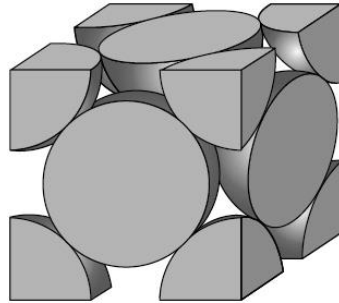
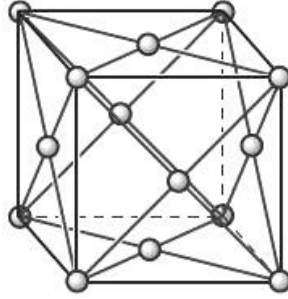

Hexagonal Closed-Packed (HCP)

- Be, Mg, α -Ti, Zn, Zr, Co
- **brittle (rows of atoms cannot slide over each other)**

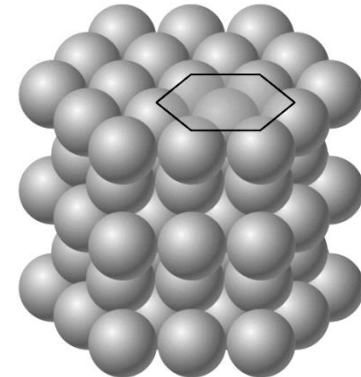
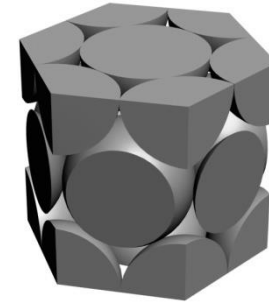
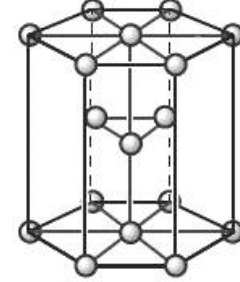



- **Atomic Packing Factor (Packing Fraction)** is fraction of volume in a crystal structure that is occupied by atoms.
- It is **dimensionless**, and **always less than unity**.

$$\text{APF} = \frac{\text{volume of atoms}}{\text{volume of unit cell}}$$

➤ Simple Cubic (SC)

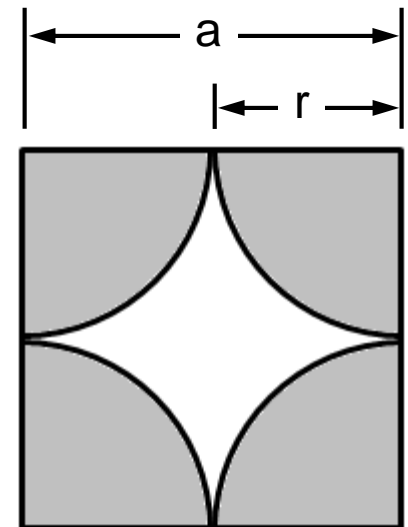
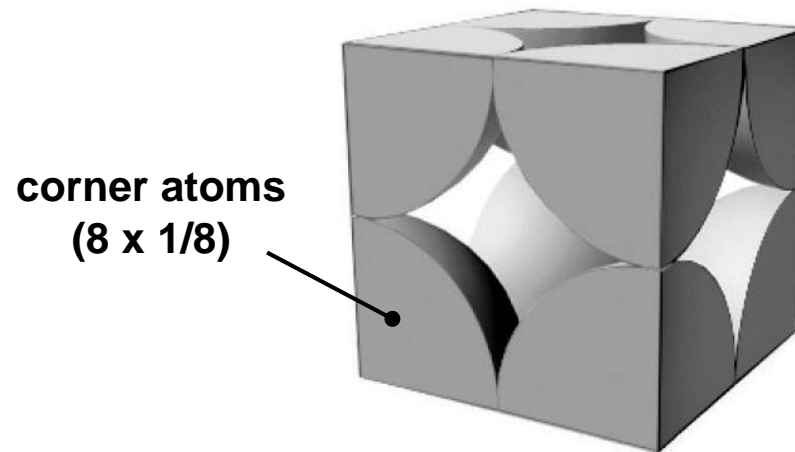

- From picture: $a = 2r$
- Total number of atoms in the cell = $8 * 1/8 = 1$
- Total volume of atoms = $(4/3)\pi r^3 * 1 = 4.19r^3$
- Total volume of the cell = $a^3 = (2r)^3 = 8r^3$
- $\text{APF} = \frac{4.19r^3}{8r^3} = 0.52 = 52\%$



► Body-Centred Cubic (BCC)

corner atoms
(8 x 1/8)

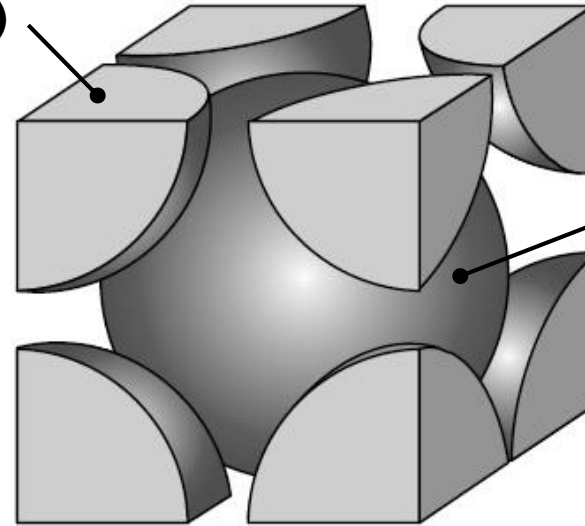

internal atom
(1 x 1)

- From picture: $3a^2 = (4r)^2 \rightarrow a = 2.31r$
- Total number of atoms in the cell = $8 * 1/8 + 1 * 1 = 2$
- Total volume of atoms = $(4/3)\pi r^3 * 2 = 8.38r^3$
- Total volume of the cell = $a^3 = (2.31r)^3 = 12.32r^3$
- $APF = \frac{8.38r^3}{12.32r^3} = 0.68 = 68\%$

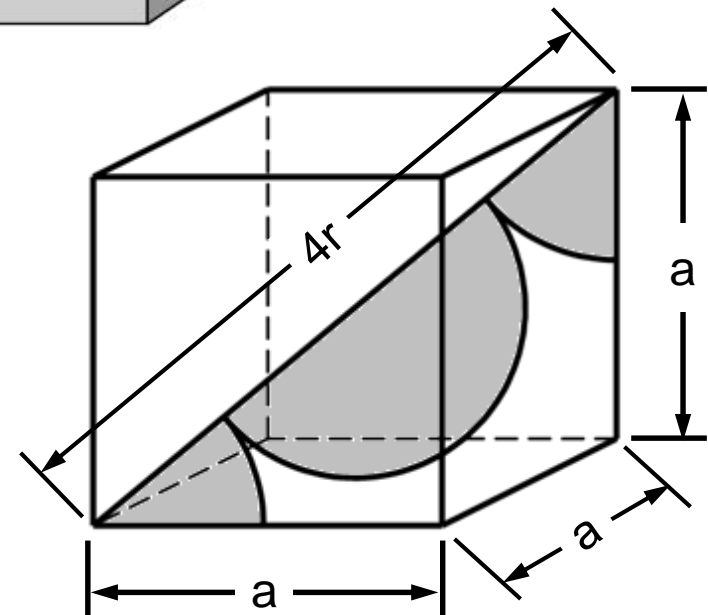



► Face-Centred Cubic (FCC)

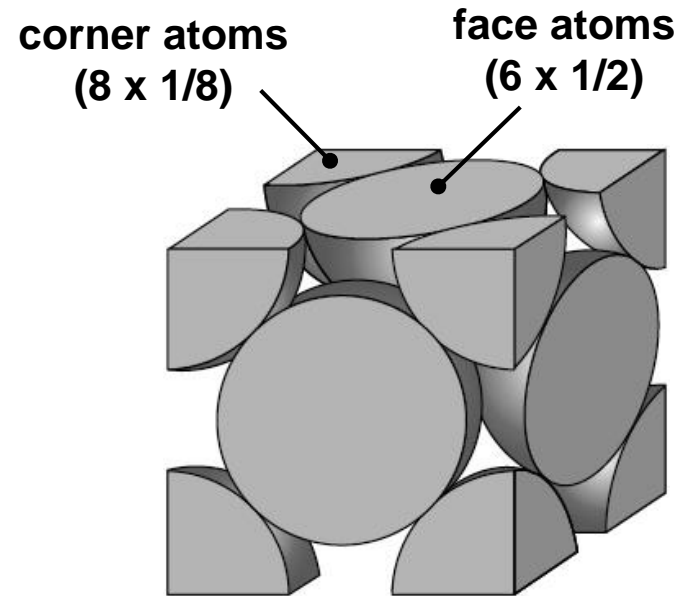

- From picture: $2a^2 = (4r)^2 \rightarrow a = 2.83r$
- Total number of atoms in the cell = $8 * 1/8 + 6 * 1/2 = 4$
- Total volume of atoms = $(4/3)\pi r^3 * 4 = 16.76r^3$
- Total volume of the cell = $a^3 = (2.83r)^3 = 22.72r^3$

- $APF = \frac{16.76r^3}{22.72r^3} = 0.74 = 74\%$

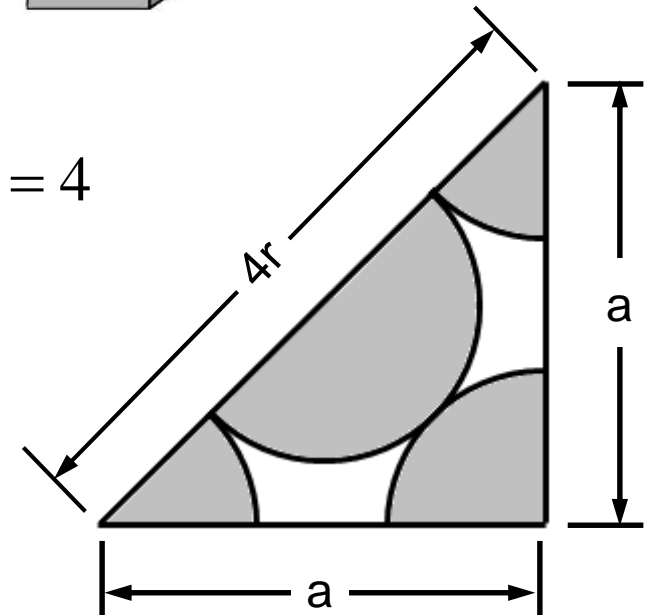



► Hexagonal Closed-Packed (HCP)

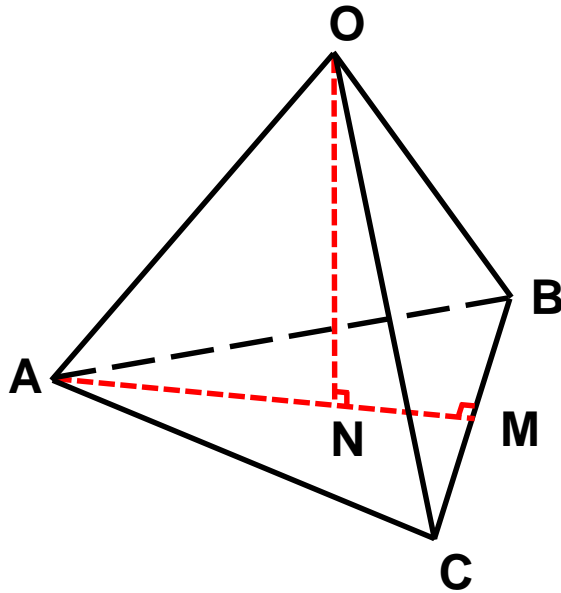

$$AB = BC = AC = a$$

$$BM = CM = a/2$$

$$AM = a * \sin 60^\circ = \left(\frac{\sqrt{3}}{2}\right)a$$

$$AN = \left(\frac{2}{3}\right)AM = \left(\frac{\sqrt{3}}{3}\right)a$$

$$AO = a$$

$$ON = \sqrt{(AO)^2 - (AN)^2} = 0.8165a$$

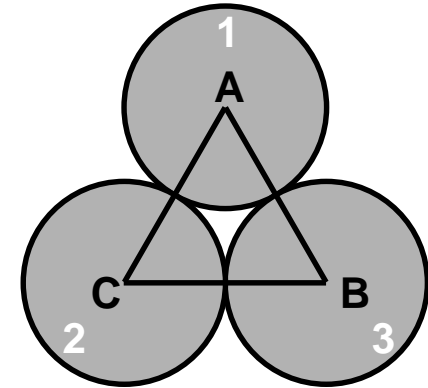

- From picture: $a = 2r$
- Total number of atoms in the cell = $12 * 1/6 + 2 * 1/2 + 3 * 1 = 6$
- Total volume of atoms = $\left(\frac{4}{3}\right)\pi r^3 * 6 = 25.14r^3$
- Area of basal hexagon = $6 * (\text{area of } ABC) = 6 * (BC * AM / 2) = 2.6a^2$
- Total volume of the cell = $(\text{height of hexagon}) * (\text{area of basal hexagon})$
 $= (2 * ON) * (2.6a^2) = 4.24a^3$

$$\bullet \text{ APF} = \frac{25.14r^3}{4.24a^3} = \frac{25.14r^3}{33.94r^3} = 0.74 = 74\%$$

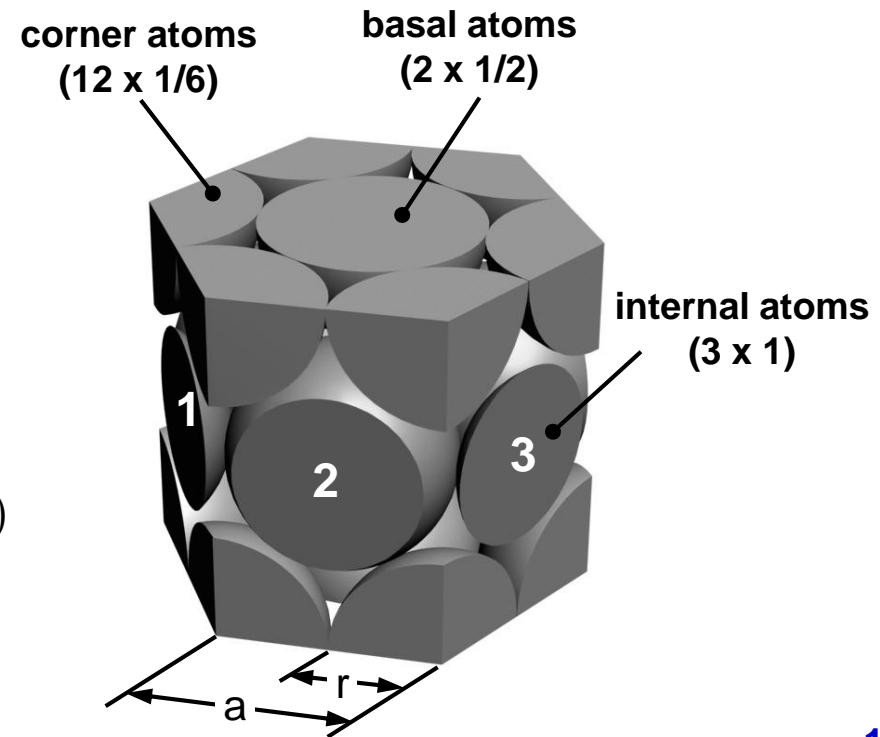



- **FCC and HCP structures (but not BCC)** are obtained when **layers of atoms are stacked on top of each other in a specific manner**. When solidification of molten metal occurs, the metal atoms join together to form layers and **these layers sit on top of each other** (in a similar manner to a packet of sliced bread in which bread slices are stacked on top of each other).
- Figure shows closely packed layers and stacking sequence in which atoms of layer 2 sit in the pockets produced by three adjoining atoms of layer 1.
- This 1-2 arrangement leads to very close packing of atoms. The same close packing can also be obtained if the atoms of layer 3 occupy the pockets produced by three atoms of layer 2 instead of three atoms of layer 1.
- Thus, a close packing can be obtained by stacking atoms on top of each other in 1-2, 1-3, 2-3 fashion, but not on top of atoms like 1-1 or 2-2. **FCC lattice is obtained by a sequence 123123** whereas **HCP is obtained by a sequence 121212**. As in figure, stacking of atomic layers in FCC takes place on a plane which is at 45° to the sides of the cube.

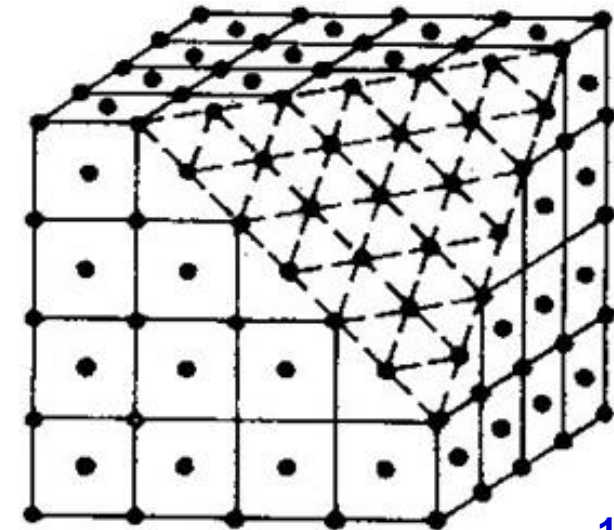
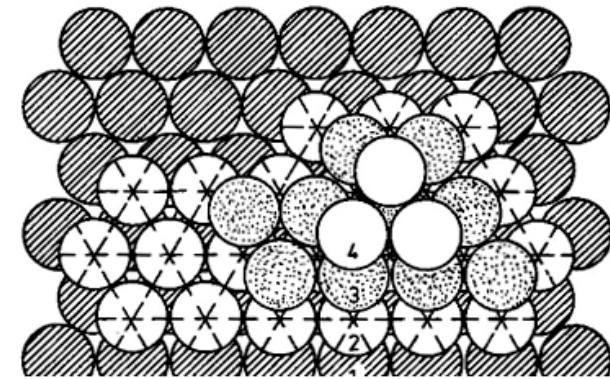



- Structure of a unit cell plays very important role in determining the characteristics of a metal, as mechanical properties of a metal are related to the way that atoms are packed in a lattice.
- Atomic arrangements in unit cells give rise to **certain planes and directions** in the lattices which are **more closely packed than others**, and thus they are **easy to slip or deform**.
- To understand mechanical characteristics of a particular structure, it is **essential to identify such planes and directions**. They are described by set of numbers, known as **Miller indices**.
- **Paranthesis** are used to describe one plane while **brackets** are used for family of planes.
- **Negative numbers** are denoted by a bar, e.g. $(10\bar{1})$

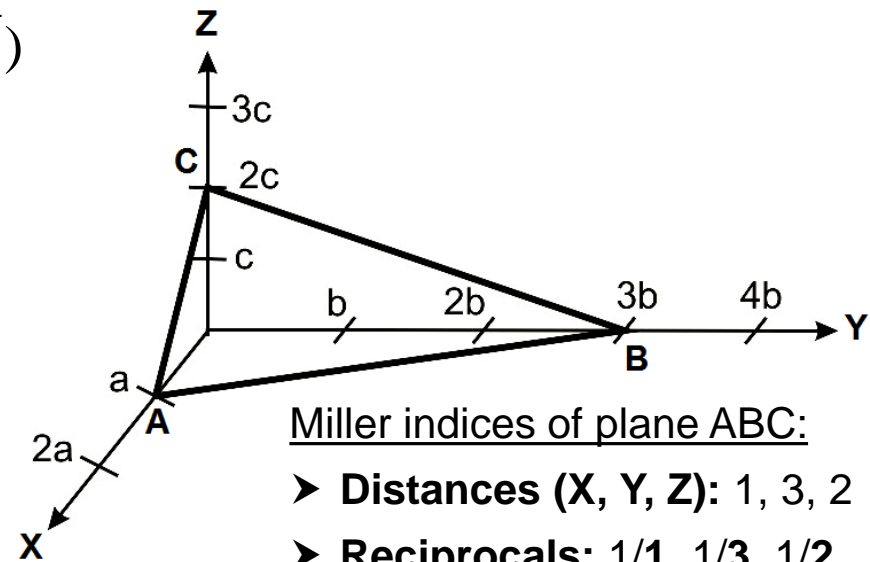
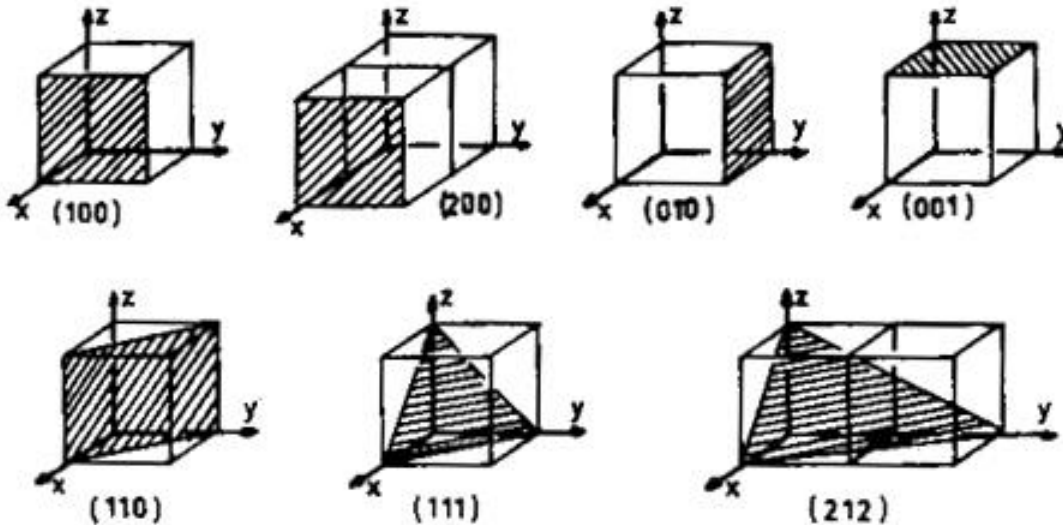

Miller indices of plane ABC:

- **Distances (X, Y, Z):** 1, 3, 2
- **Reciprocals:** $1/1$, $1/3$, $1/2$
- **Normalize:** $6/6$, $2/6$, $3/6$
- **Miller indices:** **(623)**



- **Directions** are given according to the distance travelled along the three axes to reach from the start of the direction to its end.
- They are given in **rectangular brackets** (**angular bracket** is used for a family of directions).
- **Certain relationships exist between planes and directions in the cubic system.** For example, **the direction [111] is normal to the plane (111).**

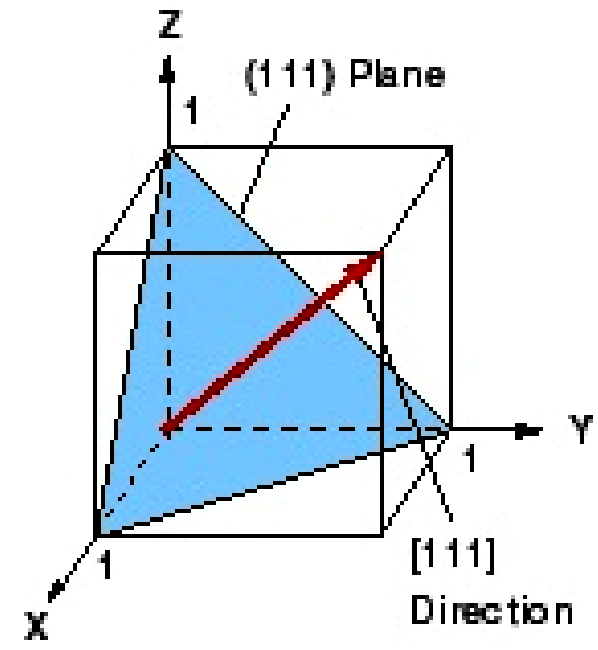
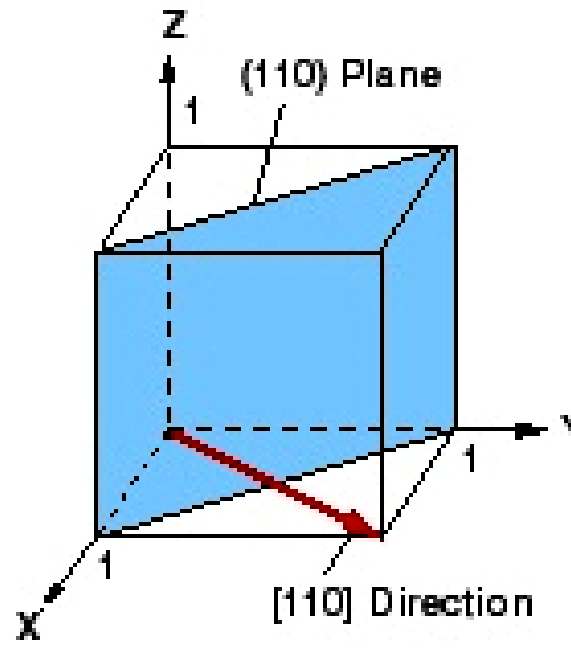
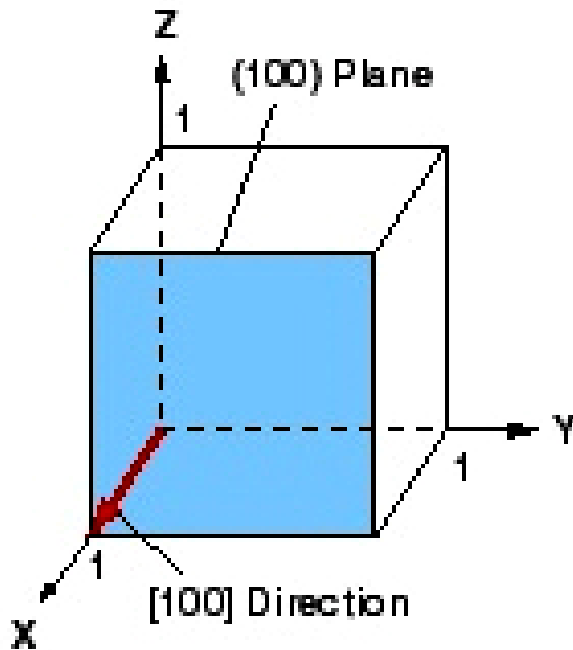



- They are used to describe **all possible planes for a particular structure** by using an imaginary sphere whose center is occupied by the structure in question.
- Normals from each plane intersect the imaginary sphere at some point (P), and **projection of that point on the equatorial plane (P')** describes that plane in the stereograph.

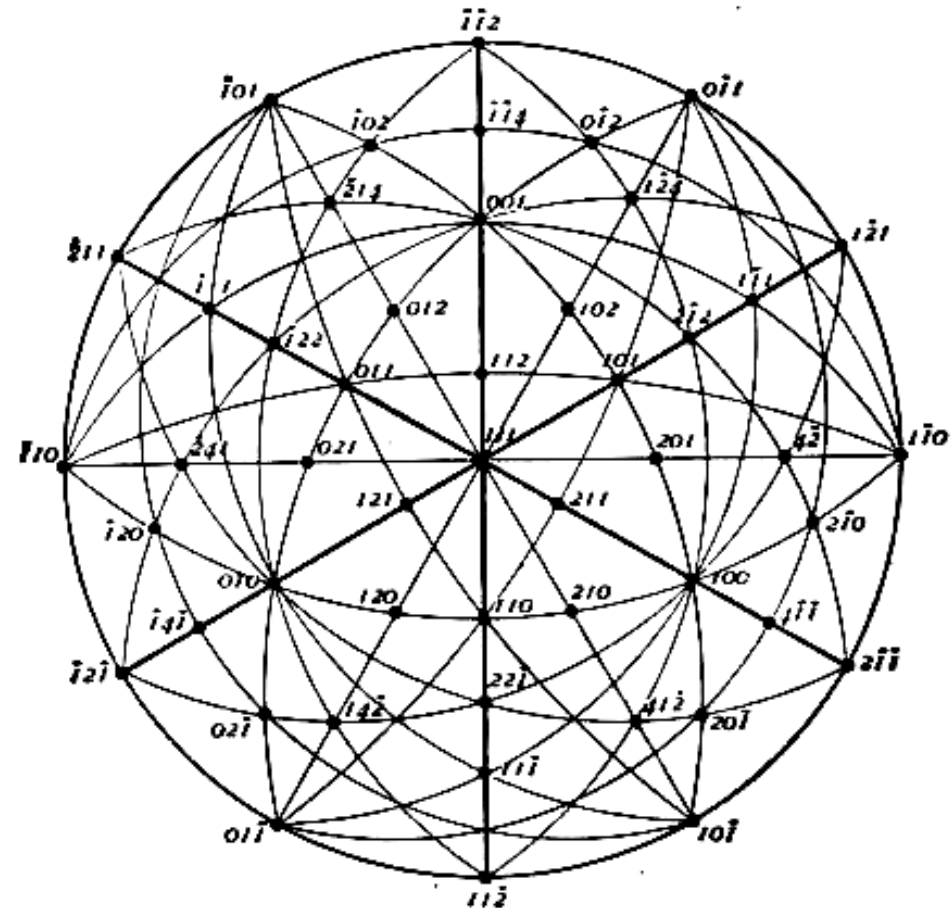
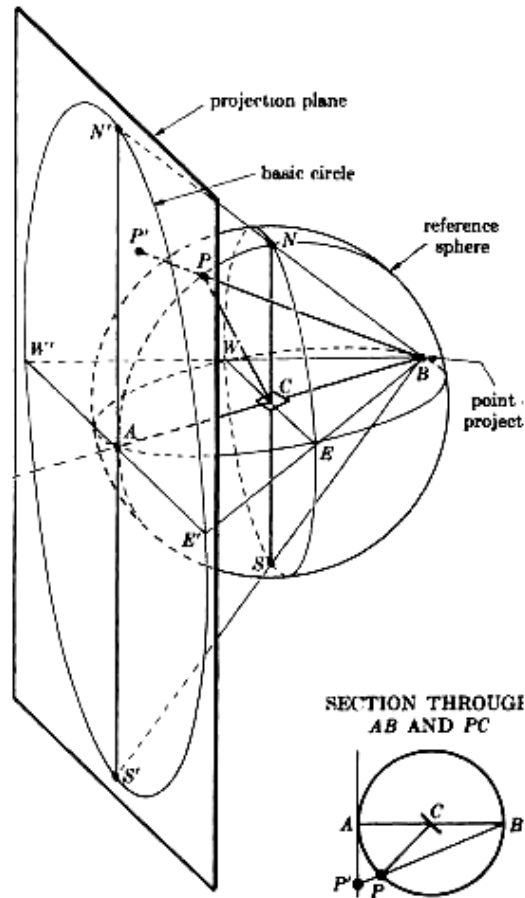



- The way in which an alloying element may change structure of the parent metal (and also structure of the alloy as a whole) and the degree of solubility of two elements depends upon **the atomic structure of elements, their relative sizes and valencies**.
- Depending upon the nature of alloying element and parent metal as well as the temperature, the alloy may exhibit **a solid solution**, in which two elements are completely dissolved in each other. Sugar and water are dissolved in each other in liquid state (**liquid solution**). Alternatively, the elements **may not be dissolved** and may exist as two separate phases.
- **Steel** is the most common example of **an alloy of iron and carbon** which exhibits **complete solubility** in **ferrite** solid solution (below 723 °C), **austenite** region (between 723-1401 °C), and a two-phase region of ferrite and cementite (which is called **pearlite**).
- **A solid solution resembles a liquid solution** as it preserves inter-atomic state of liquid form, and the atoms of two elements are intermingled with each other. However, being in a solid crystalline state, this mixing is based on a definite arrangement which is usually a **distorted structure of one of the two constituent elements**.



- **A complete solution** is obtained if the two elements have **the same lattice structures, nearly equal atomic diameters, and equal number of valence electrons**.
- If **difference in atomic diameters** exceeds 14-15%, then the range of solubility is restricted because of distortion caused by the misfit due to diameter difference. **Lead and antimony** have a large difference in their diameters (lead has an atomic number of 82 compared to 51 for antimony); consequently they **do not dissolve in each other at all**.
- A large **difference between the electronegativity** of two elements also reduces solubility since they will tend to form intermetallic compounds rather than solid solution. **Aluminum** and **copper** have an electrode potential of -1.67 and +0.34, respectively. Due to this large difference in electronegativity, they tend to form **an intermetallic compound (CuAl₂)**.
- Furthermore, an element of lower valency dissolves a metal of higher valency more readily than the vice versa (**relative valency effect**). **Silicon (valence 4)** dissolves little **copper (valence 2)** whereas copper dissolves an appreciable amount of silicon.



- The intermingling of solute and solvent atoms in a solid solution structure can be one of many types. **Substitutional solid solutions** are those in which the solute (alloying element) atom occupies one of the lattice positions of the solvent (parent) metal matrix.
- In most alloy systems, this substitution is disordered whereby substitutional atoms occupy lattice positions indiscriminately in the proportion required by chemical composition of alloy. However, in some cases (e.g. **Au-Cu alloy system at low temperatures**), the substitution is not random but orderly such that the solute atoms form a pattern superimposed on structure of the solvent matrix. This superimposed pattern is called a **superlattice**. In some alloy systems such ordering increases the strength of metal.
- If solute atoms are very small compared to solvent atoms, they have a tendency to sit in the spaces between solvent atoms (i.e. **interstices**). This solution is called **interstitial solid solution** (e.g. small atoms of **boron, nitrogen, hydrogen, carbon** have tendency to form such solution).
- In general, the size of solute atom is half of that of solvent atom. In some alloys, both substitutional and interstitial solid solutions occur simultaneously.

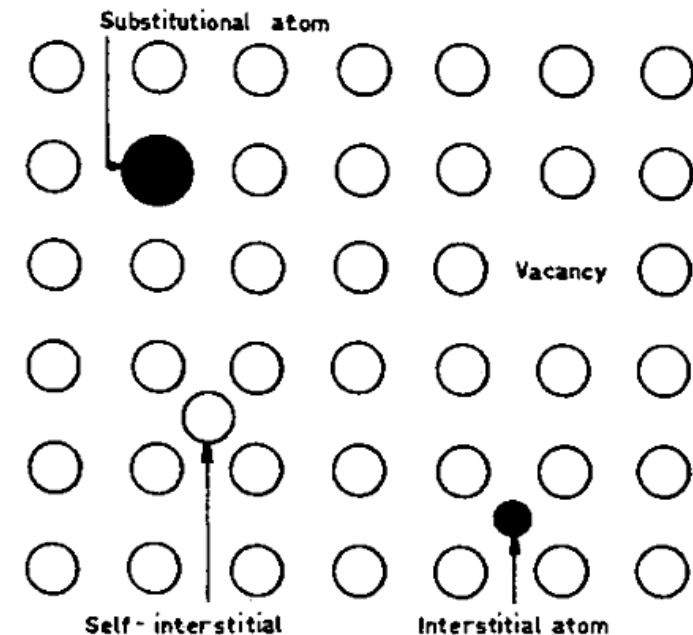



- Metals and alloys do not possess perfect crystal structures. **Imperfections are inherently present in their matrices.** These matrix defects play **a very important role in deformation of metals and alloys**, and consequently their presence alters the mechanical properties of engineering materials and alloys.
- **Defect** is a general term covering **all types of lattice imperfections**. They are classified as: **point defects** (*vacancies, interstitials, substitutionals*), **line defects** (*dislocations*), **surface defects** (*plane defects*)

Point Defects

- They are **atomic defects**. In some cases, due to high temperature vibrations, an atom of parent matrix is displaced from its site creating **a vacancy**, and another atom may occupy an interstitial site (**self-interstitial**).

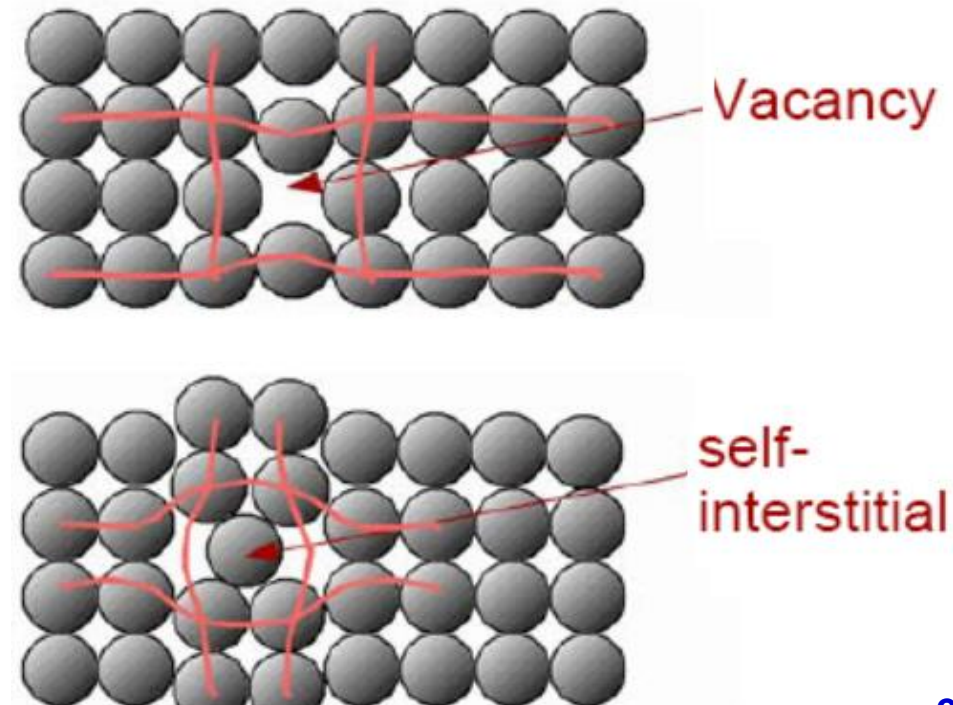



Line Defects

- Line defects are long in one direction while only a few atomic diameters wide.
- **Dislocation** is a line defect which is an extra half plane of atoms inserted between atomic planes in a crystal.
- **Edge dislocation** has an extra half plane running parallel to the direction of dislocation.
- **Screw dislocation** has also an extra half plane of atoms, but it moves under a shear stress.

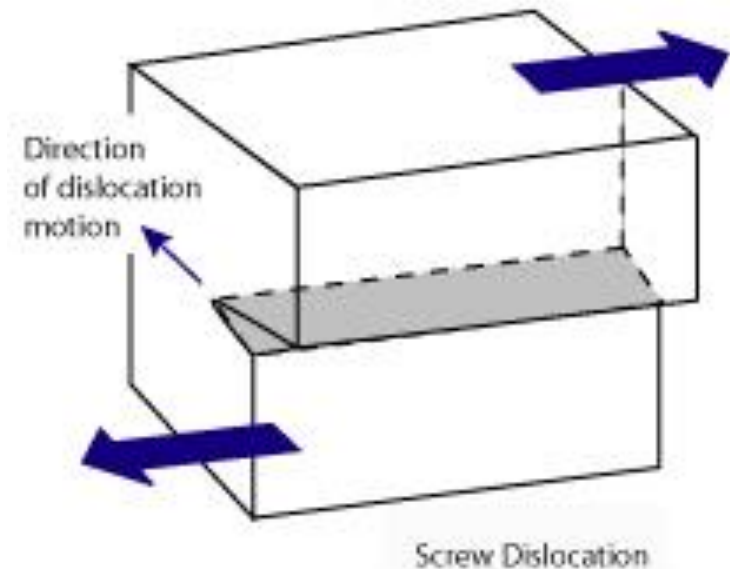
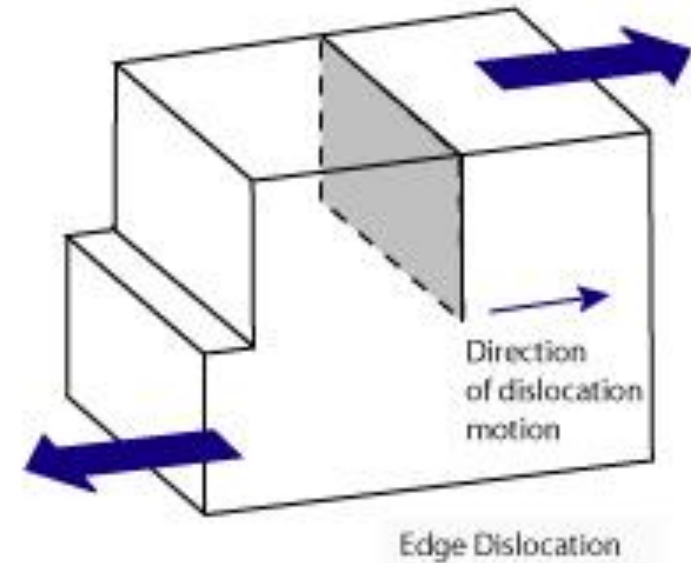



Planar Defects

- These are large defects of few atomic diameter thickness occurring inside crystal structure. They are classified as: **grain boundaries**, **twin interfaces**, and **stacking faults**
- **Grain boundaries** are **areas of mismatch** produced due to a difference in orientation of neighboring space lattices. They are associated with high energy.
- **Twin interfaces** are planes across which atoms are arranged to form a mirror image of each other. They are produced as a result of deformation (**deformation twins** found in many HCP metals) or produced during growth of crystal (**annealing twins** found in many FCC metals).
- **Stacking faults** are **similar to twin interfaces**, except that after a fault in the sequence of stacking (such as sequence of ABCAB[C]BCABC) it is not reversed, but continues in the same way to produce the faulty configuration.