

ME 216 – Engineering Materials II

Chapter 2

Metallurgical Examinations

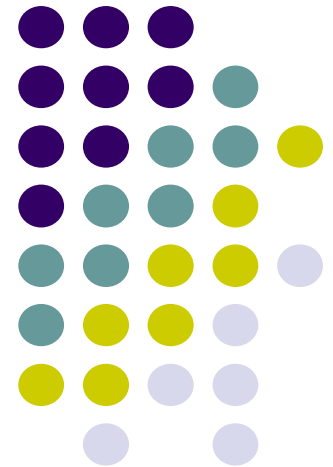

Mechanical Eng. Dept.
Gaziantep University

Prof. Dr. Ömer EYERCİOĞLU
Prof. Dr. Ali Tolga BOZDANA



- A prerequisite for study of metals is **tools & techniques** to examine aspects of metal science.
- These are necessary for **examination of materials** and **altering & treatment of metals**.
- These techniques can be classified into three broad categories: **Macro**, **Micro**, **Analytical**

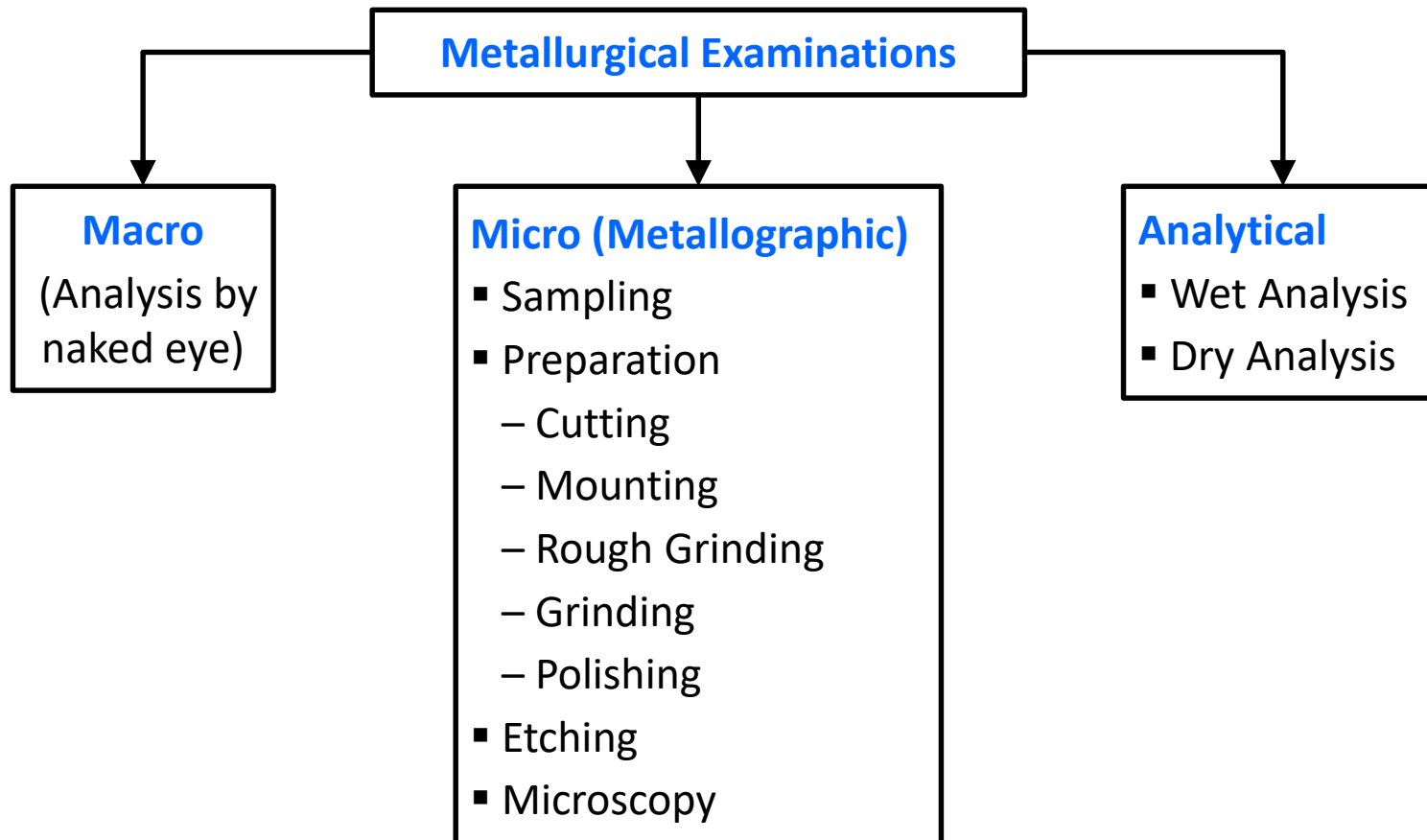



- Macro examinations are the observations **made on a relatively large scale** such that they can usually be carried out **by naked eye**.
- They do not involve detailed study of microstructure.
- **In general, micro examinations follow macro examination.**
- Macro examinations are used:
 - **to test the suitability of a metal** before putting it in service
 - **to identify the causes of any undesirable features** in a metal
- Sophisticated equipment are not required, and they can be performed on site if necessary.
- These tests yield the following information:
 - **Source of fracture or crack initiation**
 - **Inhomogeneity, inclusions, second phase segregation**
 - **Casting defects** such as blow holes and shrinkage cavities
 - **Weld defects**
 - **Plastic deformation**
- There are various means of macro examination depending upon type of information sought and type of material. For each case, it is very important to select an appropriate sample and prepare the surface accordingly.



- Etching is a **chemical process** in which a clean polished metallic surface is subjected to **chemical attack by a suitable reagent (etchant)**.
- The reagent attacks areas of the metal surface selectively depending on the energy levels.
- High energy areas (**grain boundaries, cavities, strained fields**) are preferentially attacked.
- Such attacks dissolve the material from these areas making the polished surface uneven, and thus **such areas become highlighted and observable**.
- If metal is kept in the reagent for too long (**over-etching**), entire surface will be chemically attacked and the distinction between desirable features and rest of the surface will be lost.
- **Under-etching** would not allow enough attack, and the features will not be distinguished.
- Therefore, proper etching times are a matter of **trial-and-error**, and experience dictates how etching time is obtained.
- Etching is performed **either by dipping sample in the solution** for a specified time **or solution is spread over the sample**.
- The specimen is washed with water and alcohol, and dried before examination.



- **The choice of reagents** may vary based on the type of metal and feature. The following list is a **generalized range of etchants for steel**:

<p><u>Deep etching:</u></p> <p>Hydrochloric acid (140 ml) Sulphuric acid (3 ml) Water (50 ml)</p> <p>Etching temp. of 90 °C for 15-30 minutes.</p>	<p><u>To reveal plastic deformation (Fry's solution):</u></p> <p>Cupric chloride (90 g) Hydrochloric acid (120 ml) Water (100 ml)</p> <p>Heat the specimen to 200-250 °C prior to etching, and etch for 2-24 hours</p>
<p><u>To reveal segregation:</u></p> <p>Iodine (10 g) Potassium Iodide (20 g) Water (100 ml)</p>	<p><u>To reveal structural variations:</u></p> <p>Ammonium persulphate (10 g) or nitric acid (10 g) Water (90 ml)</p>

- Specific reagents for particular cases may be obtained from **Metals Handbook**. The details obtained from macro etching **can be recorded by photography** if needed.



- Sulphide print may be used **to identify sulphides** that are a class of detrimental inclusions and second phase particles.
- During printing, sulphides are attacked by dilute acids and hydrogen sulphide gas is evolved. **Hydrogen sulphide gas stains the bromide paper.** Therefore, if a sulphide containing metal is dipped in a dilute acid and then put in contact with bromide paper, **an imprint of areas of sulphides will be obtained on the bromide paper** due to evolution of hydrogen sulphide gas.
- The procedure is as follows:
 - Prepare a clean polished surface using abrasive paper.
 - Soak the bromide paper in water with 3% sulphuric acid for 2 minutes.
 - Take the paper out and remove the excess solution using blotting paper.
 - Stick the paper on polished metal surface and stroke it so that air bubbles are removed.
 - Leave it for 1-2 minutes until brown stains can be seen on peeling the paper on one end.
 - Remove the paper and wash it in water for 3 minutes.
 - Put the paper in 20% hypo solution for 5 minutes.
 - Wash it in water for 20 minutes and dry.
 - Dark room is not required, and a print is obtained which gives the distribution of sulphides.
- Sulphide prints **cannot be used on high alloy steels and nonferrous metals.**



- An appropriate diagnosis of causes of failure can be carried out by macro examination.
- **Information obtained from etching or sulphide print may be used for this purpose.**
- An initial idea about type of failure can be obtained by **the appearance of fracture surface** which is characteristic for ductile, brittle, fatigue, and cleavage failures.
- Then, the actual cause can be determined by examining **the crack initiation site**. These are areas where the cracking starts and propagates up to the final fracture. Cracks could initiate from inclusions or second phase particles, corrosion pits, pores or cavities produced during casting, internally strained areas due to bad design, or faulty fabrication.
- Macro examination would give a reasonably accurate picture which can be confirmed by undertaking a micro or metallographic examination.



- **Metallography** is the most important procedure for a metallurgist, material scientist, or engineer dealing with metals.
- In a broad sense, it is **a method of observing the structure of metal through its surface**.
- In recent years, it has developed to **include internal examinations as well**, especially after the advent of electron microscopy.
- **Metallographic examinations** can be carried out:
 - **On plain surfaces** to study micro-structural details
 - **On fractured surfaces** to study the mode of cracking and failure of metals
- The purpose of such examinations is to obtain information for determining characteristics of that particular material.
- The factors affecting the accuracy of these examinations are **sampling**, **preparation** and **microscopy**; and each of these is important in its own right.



- The importance of sampling is due to the fact that **metals are heterogeneous structures**.
- Heterogeneity denotes **non-uniformity of properties and structure along various directions**.
- Consider a piece of metal shown in figure. **Two structures taken from transverse and longitudinal directions show different grain shapes**.
- Such variations might result from **mechanical working** (e.g. rolling) or **inherent population of inclusions in metal** (which may not be uniformly distributed).
- To minimize the effect of inclusion distribution, **a large enough sample must be selected** which would even out any non-uniformity.
- Moreover, **cross-section of sample must be recorded**, and accounts for the effect of rolling.

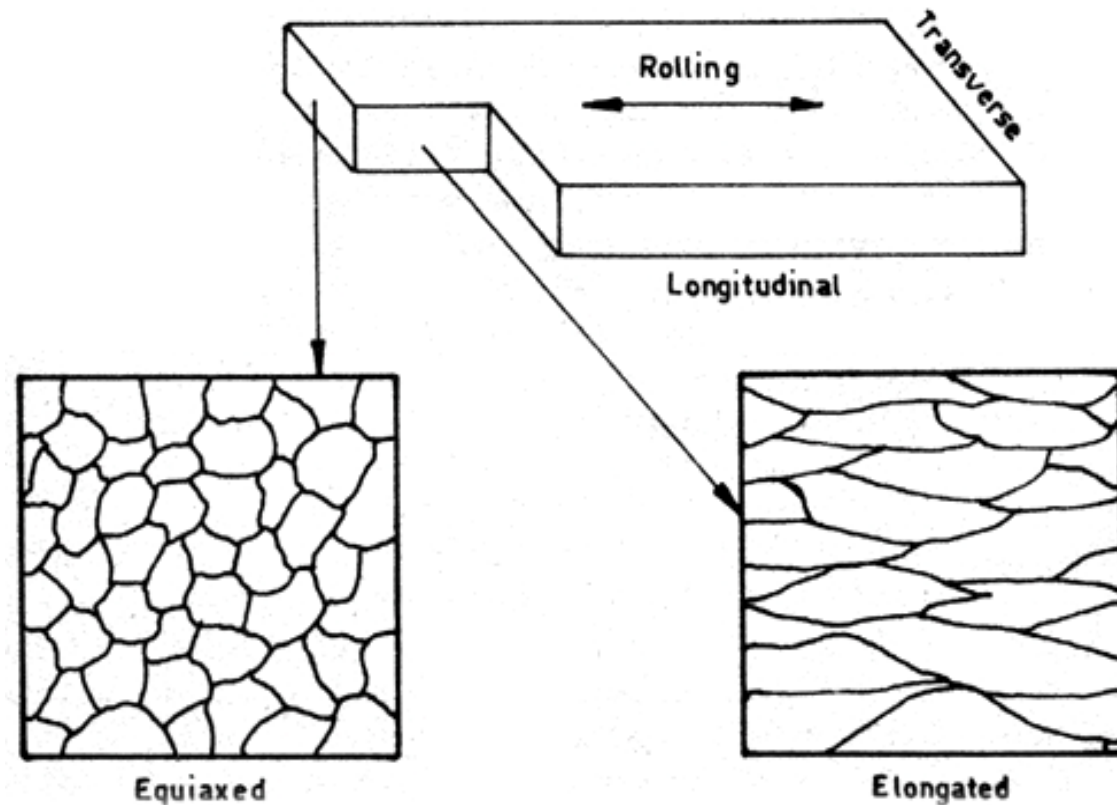



Isotropy: identical properties in any direction

Anisotropy: properties vary with direction

Single Crystals

Anisotropic



Modulus of Elasticity (E)
in BCC iron:

$$E_{\text{diagonal}} \neq E_{\text{edge}}$$

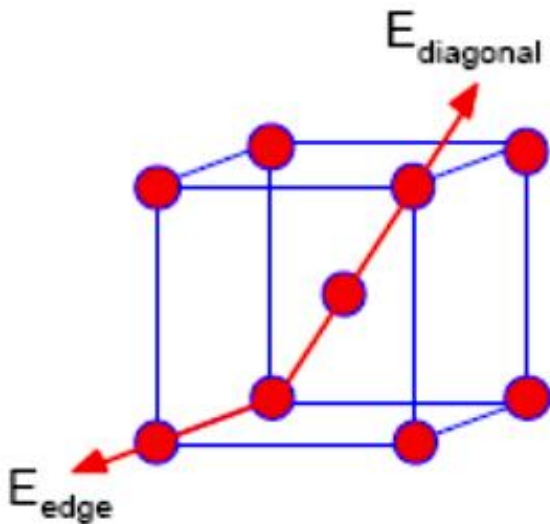

Polycrystals

Isotropic



Grains are randomly oriented

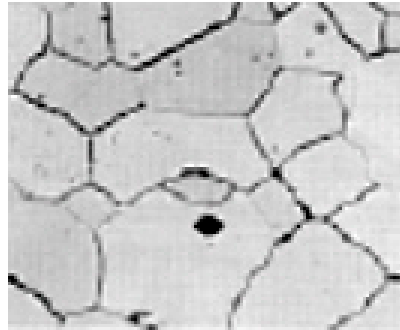

Polycrystals

Anisotropic



Grains are textured

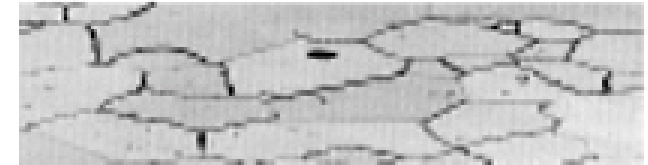



- There are **many ways of cutting a sample** from a bulk piece.
- The method to be used is dictated by **the type of metal** and **the type of analysis**.
- An ordinary sample for routine metallography may be obtained using **hacksaw (or other types of saws)**, but it cannot be done for a metal containing small inclusions or second phase particles. In such case, some of the inclusions may be lost rendering the analysis unreliable.
- **Laser or spark cut** (with minimal loss of material) is more appropriate for such metals. Laser machines use laser beams for cutting whereas electrical sparks are used in spark cutting machines.
- In summary, the choice of cutting method should be made in view of metal characteristics and the objective of final examination.
- In all cases, **the specimen must not be overheated** during cutting as it may lead to a change in microstructure.



➤ Specimen preparation is done by manual polishing of metal surface. For this purpose, **the sample is mounted for easy handling during polishing.**

➤ Mounting is done **either using heat** with thermoplastic resins (such as polystyrene or methyl-methacrylate) **or by cold** thermosetting epoxy resins.

a) Hot mounting: Specimen is placed on a platform enclosed in a cylinder where surface to be observed is facing down. The cylinder is filled with resin, heated to 230 °C, and compressed at the same time. The resin is sintered around the specimen, and mounting is done.

b) Cold mounting: Specimen is placed as facing down in a mold, a mixture of thermosetting epoxy and hardener is poured, and it rests for a specified time during which the epoxy hardens to produce a cold mount.

➤ Finally, the mounted sample is ground and polished for microscopic observations.

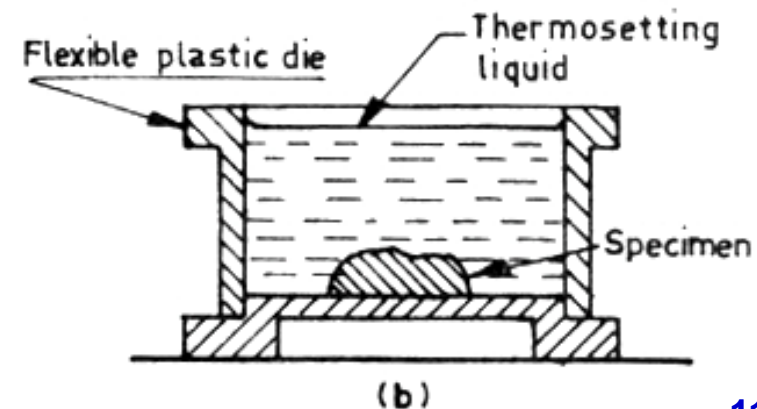
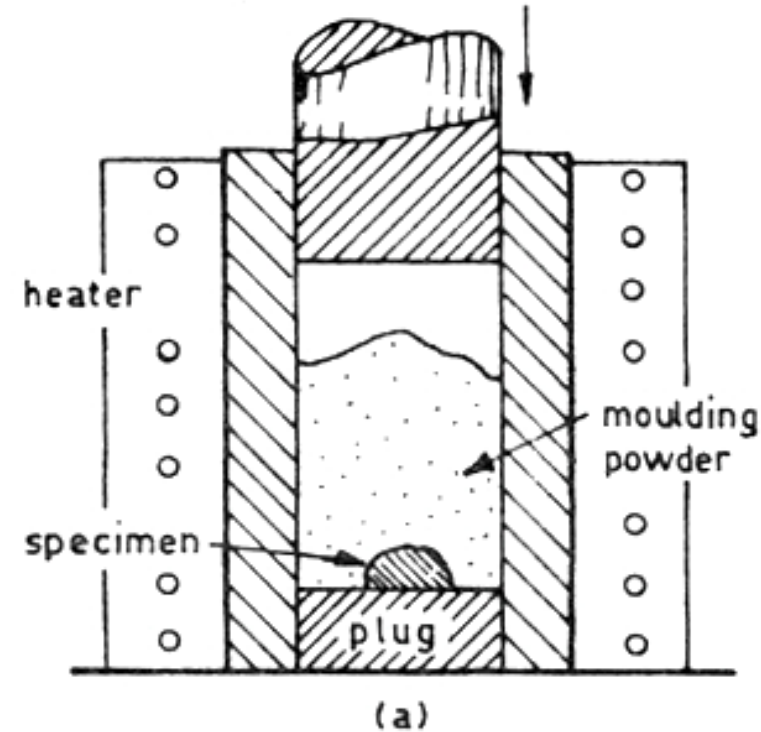

Rough Grinding (Kaba Taşlama) & Grinding (Zimparalama)



- For microscopy, the metal surface has **to be polished to an excellent finish**.
- **The initial surface is rough** due to cutting, and it needs smoothing to reduce grinding time.
- **Rough grinding** is usually carried out on **a belt sprinkled with abrasives**. Specimen is held stationary, and movement of belt causes the abrasive to grind the surface to a smoothness which depends upon the mean distance between the abrasive particles.
- On the other hand, in **grinding (fine)**, the abrasive medium has progressively finer finish.
- In general, series of **silicon carbide (SiC) coated paper (emery paper)** is used in the order of **120, 240, 360, 600 grades (which represents an increase in fineness)**. Strips of paper are mounted on a glass holder, and the specimen is ground in running water.
- Surface is **ground at right angles** to the previous scratches so that old and new scratches could be distinguished. Grinding is continued until previous scratches are replaced by new scratches which are finer due to fineness of grinding paper.
- Specimen is **washed and dried before transferring to next paper** so that any abrasive particles stuck on the surface do not impair further grinding.

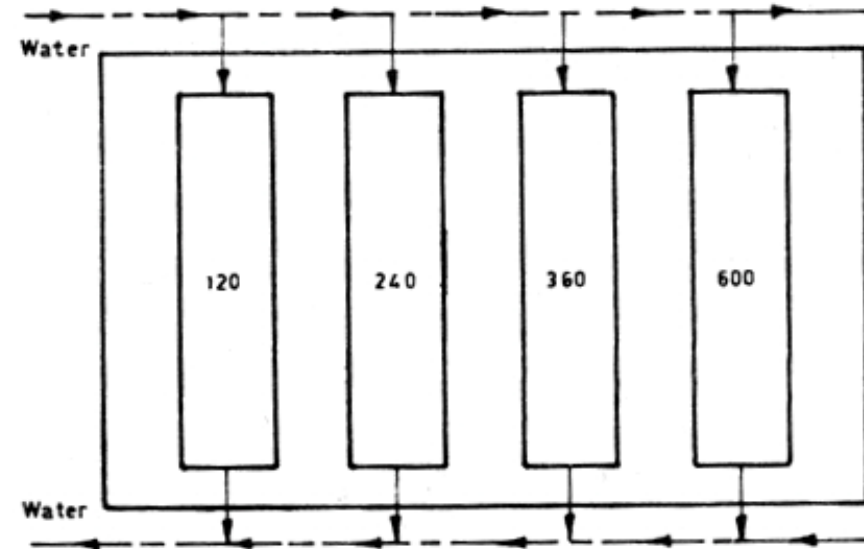



➤ The fineness of grinding paper (grit) has a wide range, as shown below:

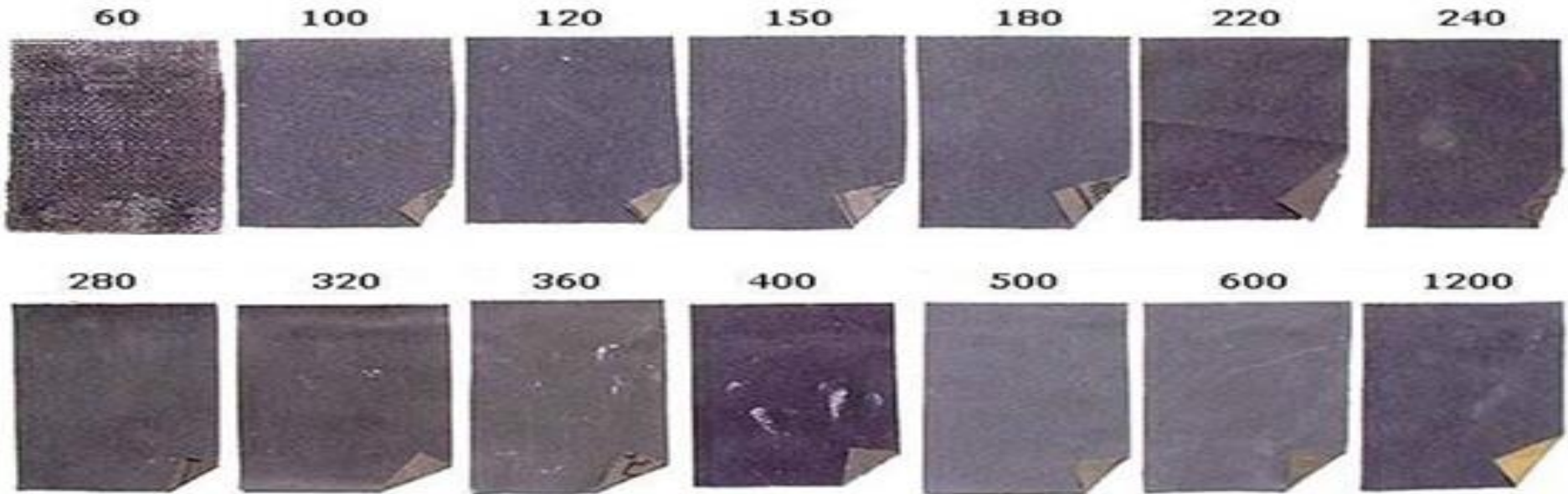

➤ A metal surface ground by papers with various grits is shown below:



60 grit Premium SIC

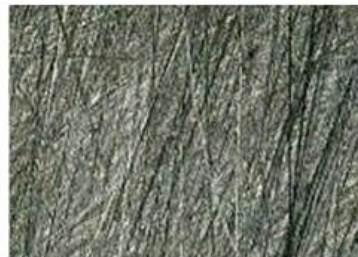

240 grit Premium SIC

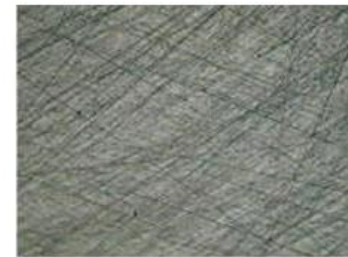

400 grit Premium SIC



600 grit Premium SIC



- Final polishing can be done by two methods: **rotating-disc polishing** or **electrolytic polishing**
- **Rotating-disc polishing** uses **fine flakey diamond powders** on broad cloth (çuha), chamois leather (dağ keçisi derisi) or velvet (kadife) on a motor operated disc.
- Specimen is **held down & moved slowly against direction of rotating disc**.
- **Diamond dust paste** is put on disc at the beginning of polishing, and **kept moist** with mixture of powder & water.
- Diamond dust is used for hard metals (such as steels), but other powders (e.g. alumina Al_2O_3 , green chromic oxide, magnesia) may also be used.
- In **electrolytic polishing**, protruding rough surface is **dissolved away chemically**.
- Specimen is **anode** while aluminum or stainless steel is **cathode**. By proper adjustment of solution, temperature, current density, voltage and time; the roughness can be removed to obtain a fine polished surface.

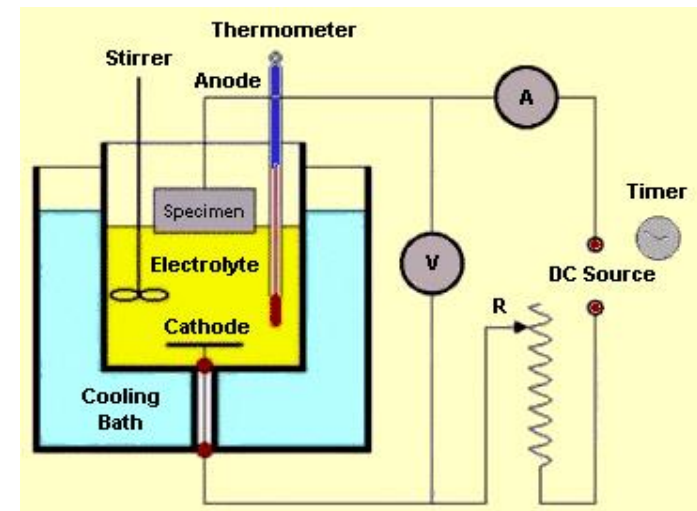



- Micro-etching is similar to macro-etching in principle except that **the etchant is different**.
- Features revealed by micro-etching are very small and **only observable under a microscope**.
- Under microscope, **light rays are reflected by smooth areas of surface** back into microscope giving shiny appearance. However, **dissolved areas appear dark** as they disperse light rays that are not focused back into microscope. This contrast makes such features visible.

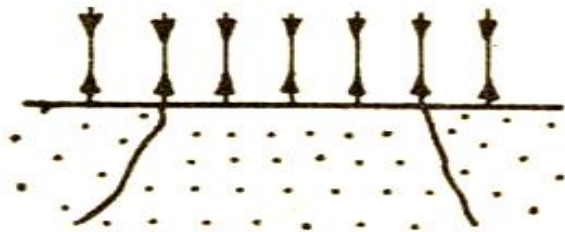

(a) unetched

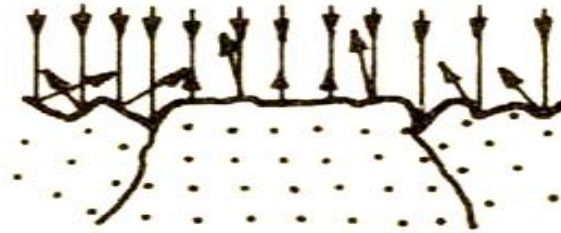

(b) etched

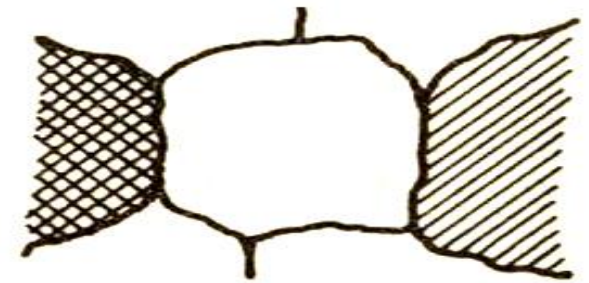

(c) picture under microscope

- Difficulties in etching are due to the followings which can easily be overcome by practice:
 - **An uneven attack** by the chemical (would make only certain features visible)
 - **Over-etching and under-etching** (as explained earlier)
 - **Stains** due to chemicals left on the surface (they decompose light to give various colors)
- Etchants are chemicals, and **may be hazardous if mishandled**. Thus, it is recommended that **protective clothing** (masks, gloves, etc.) must be worn and **fume cupboards** must be used.



➤ Short list of etchants is below (the complete list can be obtained from **Metals Handbook**):

Metal	Etchant	Composition	Etching Time
Iron & carbon steels	Nital	2-5 % nitric acid in methyl alcohol	5-60 s (for pearlite, ferrite & martensite)
	Picral	4 g picric acid, 100 ml methyl alcohol	5-120 s (for annealed & hardened steels)
	HCl & picric acid	5 g HCl, 1 g picric acid, 100 ml methyl alcohol	5-90 s (reveals austenite in quenched steels)
Alloy & stainless steels	Ferric chloride & HCl distilled water	5 g ferric chloride, 20 ml HCl, 100 ml distilled water	15-120 s (for stainless & austenitic steels)
High speed steels	HCl & nitric acid	9 ml HCl, 9 ml nitric acid, 100 ml alcohol	15 s - 15 min (for hardened HSS)
Aluminum & alloys	Sodium hydroxide	10 g NaOH, 90 ml distilled water	5 s (macro & micro etching)
Magnesium & alloys	Glycol	75 ml ethylene glycol, 24 ml water, 1 ml nitric acid	5-15 s
Nickel & alloys	Acetic acid	50 ml galacial acetic acid, 50 ml nitric acid	5-20 s
Copper & alloys	Nitric acid	12-30 % nitric acid in distilled water	5-20 min
	Keller's etchant	10 ml HF, 15 ml HCl, 25 ml nitric acid, 50 ml distilled water	5-20 s
Zinc & alloys	Nitric acid	2 % nitric acid in alcohol	15-90 s
Lead	Glycerol	40 ml glycerol, 10 ml acetic acid, 10 ml nitric acid	30-120 s
Titanium & Zirconium	HF & nitric acid	1-5 % aqueous solution of HF, little nitric acid or phosphoric acid	1-5 min



- As metals are **opaque bodies**, their metallography is carried out with **light reflecting microscopes**.
- A **metallurgical microscope** consists of an objective lens, an eyepiece lens, an illumination source, a mirror (allows light to pass through) and various adjustments.
- Light rays from illuminator are reflected to specimen surface by the mirror through the objective.
- Reflected rays from the metal surface are magnified and channeled to eyepiece by the objective which can be observed by the examiner.
- **Quality of objectives governs the quality of final image.**
- **Magnification** on a microscope depends on objective, power of the eyepiece and distance between objective and eyepiece.
- **Magnification only enlarges the features and makes them visible** (i.e. real size of features is not changed).

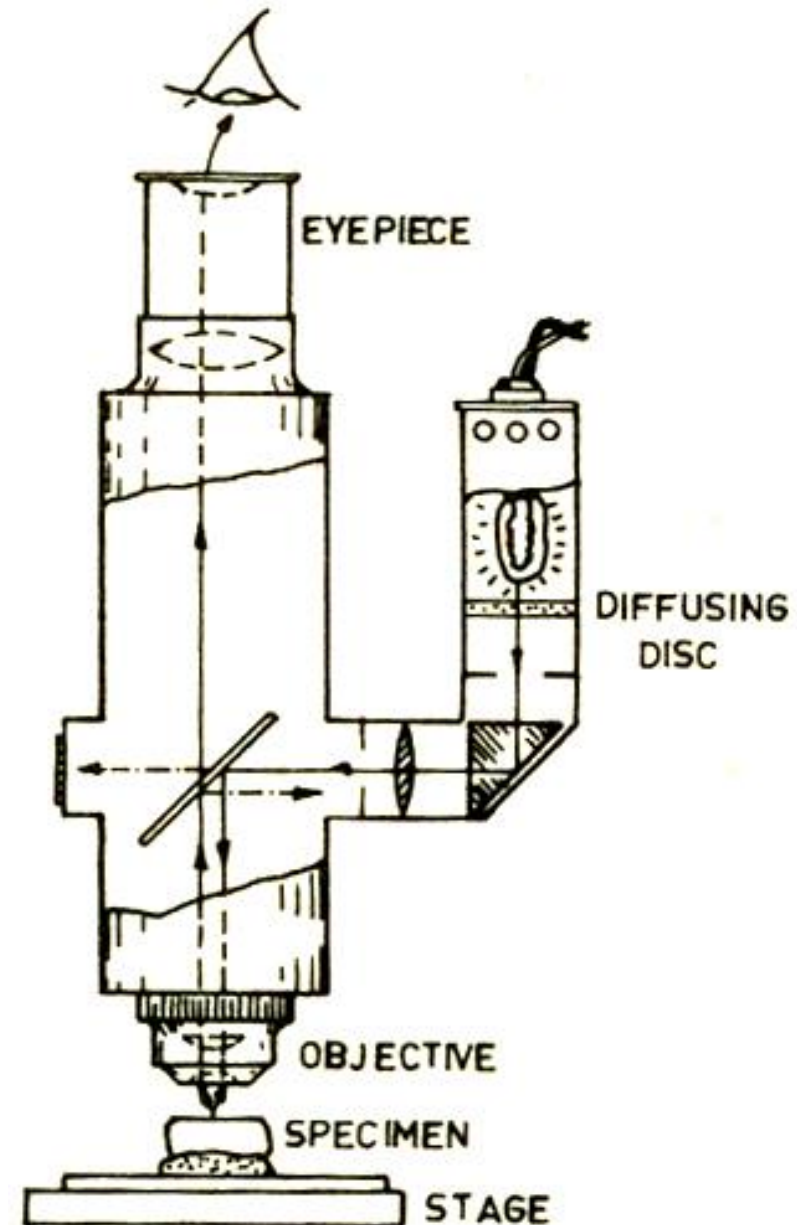



- Information obtained from macro and micro examinations is not complete as it only reveals structural features and does not provide any information on the chemistry of materials.
- Chemical analysis is very important as the chemistry of constituents plays an important role in structural and mechanistic phenomena.
- Analytical examinations to analyze a metal chemically: wet analysis & dry analysis
- Wet analysis uses chemical reagents reacting with various constituents, and the resulting products are used to identify the constituents.
- Tests are carried out in chemical laboratories, and the metal being analyzed is consumed in the process. Therefore, such tests are used for specific purposes.
- Wet analysis proves to be restrictive as the chemistry can not be related to structural details since the metal is consumed in testing and its structural observation can not be made.
- Dry analysis uses the metal non-destructively so that a simultaneous observation of structure and chemistry is possible. So, it has recently acquired a great deal of importance.
- The techniques (e.g. SEM & EDX) are based on the principle that when a beam of electrons strikes a metal surface, a variety of radiation is produced by the metal. Such radiations are characteristics of the metal, and their analysis would reveal the identity of the metal.



- Temperature measurements above **500 °C** is called **pyrometry** whereas measurements below this temperature is known as **thermometry**.
- **Thermometers** record the temperature **either mechanically** (by measuring the expansion of solid, liquid, gas, or vapor) **or electrically** (by measuring the resistance).
- **Liquid expansion thermometer** is the common mercury thermometer in which temperature change expands or contracts the mercury that rises or falls in the capillary tube.
- **Gas (vapor) thermometers** use a volatile liquid that vaporizes with increase in temperature, and pressure of vapors which depends on temperature is used to measure temperature.
- **Resistance thermometers** work on the principle that resistance of a conductor increases with increase in temperature.
- **Thermocouple** is a junction between two different metals producing a voltage related to temperature difference. It is a widely used type of temperature sensor.
- **Pyrometer** is a non-contact device that intercepts and measures thermal radiation. It is used to determine the surface temperature of an object.
- **Thermoelectric pyrometers** use a thermocouple with hot and cold junctions.
- **Radiation and optical pyrometers** work on the principle of Stefan-Boltzmann law.